



Nosyudo

濃州堂

居合道専門店

居合道専門店
有限会社 濃州堂

所在地 | 〒501-3252
岐阜県関市山王通1-11-14

TEL | (+81)575-22-2397

FAX | (+81)575-22-2383

Mail | info@nosyudo.jp

Site | <https://www.nosyudo.jp>

Open | AM9:00~PM5:30 (close Sun·Ntl Holidays)

Nosyudo co ., Ltd .

1-11-14 Sannoudori

Seki City Gifu Pref.

501-3252 JAPAN

enginfo@nosyudo.jp



2025.02 English



President of Nosyudo
Keiji Igarashi

A Word from the President

Firstly, I'd like to thank you all for your continuing support.

Under the leadership of my father, former company president Yasuo Igarashi, Nosyudo was established to make the practice swords for iaido we call "iaito".

I'm confident that the widespread use of iaito has contributed to the popularity of iaido today. In his day, the company was known as "Nosyu Iaido", taking inspiration from the old name for this region of Gifu, "Nosyu".

Seki has long-established roots as a katana town going back 700 years to Japan's Kamakura period.

Our craftsmen use the time-honored Japanese arts and techniques that were cultivated in our historic town to produce each and every sword to the highest quality possible.

In addition to spreading correct knowledge about Japanese swords in an era in which they are no longer a part of everyday life, I want to share this magnificent part of Japanese culture with the world through our swords and martial arts and ensure that the quality-first production of "Made in Japan" products continues into the future.

I can wish for nothing more than for you to enjoy using our swords for many years to come.



Contents

Introduction A Word from the President — 01

Iaito Nihonto - Parts of the Sword — 03-04

Choosing Your Iaito — 05-06

Iaito Production Process — 07-08

Shoden Iaito — 09-10

Chuden Igarashito — 11-12

Okuden Nosyusaku — 13

Okuden Shinkensaku — 14

Special Iaito

Revival Series: Famous Swords — 15-16

Revival Series: Famous Shogun — 17-18

Hamon — 19

Reference — 20-22

Shinken

Shinken - Mei — 23

Shinken Construction Examples — 24

Koshirae Examples — 25

Koshirae Iaito Shinken

Fuchi Kashira Kojiri Samples — 26-28

Menuki Samples — 29-30

Tsuba Samples — 31-34

Tsukamaki Samples — 35

Tsukaiito Color Samples — 35-36

Same Color Samples — 36

Saya Finish Samples — 37-39

Other Equipment

Other Fittings•Materials — 40-42

Other Equipment — 43-45

Books — 45

Iaigi — 46-47

How to Order — 48

Nosyudo Price Chart — 49

Iaito Repairs — 50

Iaito Repair Form — 51

Iaito Order Form — 52

Iaigi•Hakama Order Form — 53

Shinken Restoration — 54

Shinken Order Form — 55

Nosyu Sword Studio — 56

Visiting by Public Transit

※Bus only. There is no train station nearby.

From JR Nagoya Station

Express Bus (Kosoku Bus)

Required time: About 1hour 10min
Take the #23 bus on 4F at Meitetsu Bus Center for the Nagoya Seki Mino Line. Get off at "Shinden".

From JR Gifu Station

Gifu Bus

Take the Gifu Seki Line for "Seki Higashiyama" at Gifu Bus Terminal #14. Get off at "Shinden".

Visiting by car

From Nagoya

Ntl Hwy 22 (40min) ▶ Ichinomiya Kisogawa IC ▶ Tokai Hokuiriku(15min) ▶ Seki IC

From Tokyo

Tomei Expressway ▶ Toyota Higashi JCT ▶ Tokai Kanjo ▶ Tomika Seki IC

From Nagano

Chuo Expressway ▶ Toki JCT ▶ Tokai Kanjo ▶ Tomika Seki IC

From Osaka

Meishin Expressway ▶ Ichinomiya JCT ▶ Tokai Hokuiriku ▶ Seki IC

Nosyudo co, LTD

1-11-14 Sannoudori, Seki City Gifu Pref.
501-3252 JAPAN

enginfo@nosyudo.jp

Hours: AM9:00~PM5:30 Closed Sun•Ntl Holidays



The Appeal of Nihonto

Nihonto, Japanese swords, have a unique appeal.

Unlike other forms of art such as painting, it is a weapon and much more.

Unique skills and techniques are necessary to forge swords in Japan.

First, tamahagane (Japanese iron) is made by processing iron sand at low temperatures, then the iron is separated by carbon content and each piece is folded over and over again before being arranged together and combined. Depending on the method used, this process also produces the hada (patterns in the iron).

That part done, the hamon is drawn on using mud, known as tsuchioki.

Finally, yakiire (quenching) produces the hamon, sori, nie, and nioi of the sword.

The completed blade is then passed to togishi, shiroganeshi, sayashi, tsukamakishi, nushi, etc to bring a new nihonto into the world.

The balance of function and elegance as well as the shape has changed through time.

We believe the same can be said of the world of martial arts.

Nihonto are the heart of Japan. They're the soul of both the Japanese people and samurai.

We want to share knowledge of the Japan's magnificent sword culture with the world through iaido.

The Blade

- Intended use
- Length
- Sori
- Hamon
- Motohaba
- Motokasane
- Sakihaba
- Sakikasane
- Kissaki size
- Blade weight
- Bo-Hi

Fittings (Koshirae)

- Shirasaya, katana koshirae, or tachi koshirae
- Tsuka length
- Tsukaito material
- Tsukamaki style
- Tsuka grip
- Saya finish
- Fuchi, kashira
- Tsuba
- Menuki
- Seppa
- Habaki
- Weight when swung

Smith Mei

- Kanemichi
- Kanetoki
- Hiromune
- Fusataro
- Kanekuni
- Sadahito
- Shiro Kunitada
- Shiro Yasumitsu
- Shiro Kunimitsu
- So Masachika
- Akamatsutarō Kanetsugu
- Akamatsutarō Kanehiro
- Akamatsutarō Kanemitsu
- Akamatsutarō Kaneyuki
- Akamatsutarō Kazuyoshi etc

Please tell us about any special requests.

Whether you would like a sword for appreciation or for martial arts we strive to meet the needs of each of our customers.

Feel free to contact us about swords we have available in our shop or about ordering a custom sword.

Parts of the Sword

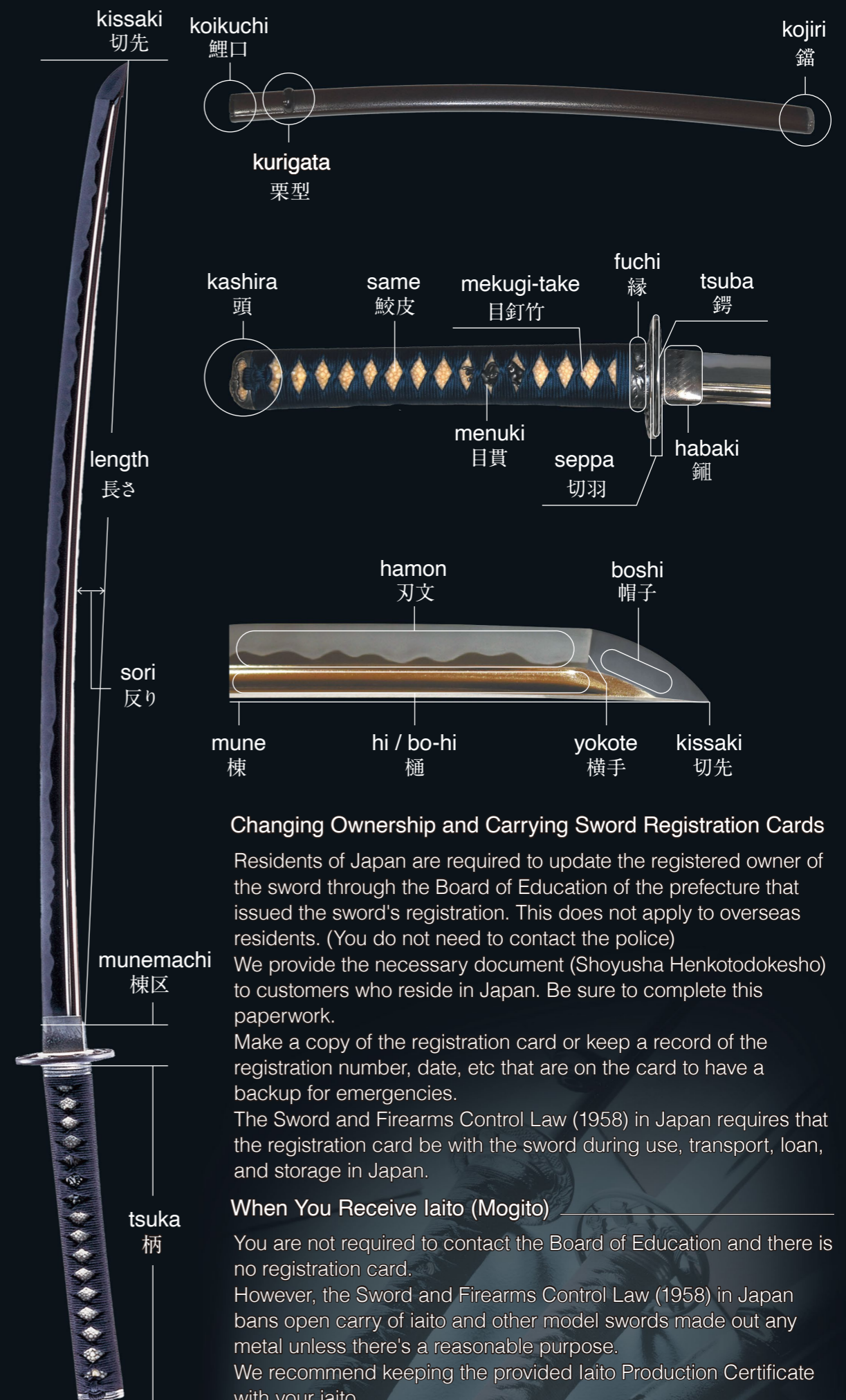

Changing Ownership and Carrying Sword Registration Cards

Residents of Japan are required to update the registered owner of the sword through the Board of Education of the prefecture that issued the sword's registration. This does not apply to overseas residents. (You do not need to contact the police)

We provide the necessary document (Shoyusha Henkotodokesho) to customers who reside in Japan. Be sure to complete this paperwork.

Make a copy of the registration card or keep a record of the registration number, date, etc that are on the card to have a backup for emergencies.

The Sword and Firearms Control Law (1958) in Japan requires that the registration card be with the sword during use, transport, loan, and storage in Japan.

When You Receive Iaito (Mogito)

You are not required to contact the Board of Education and there is no registration card.

However, the Sword and Firearms Control Law (1958) in Japan bans open carry of Iaito and other model swords made out any metal unless there's a reasonable purpose.

We recommend keeping the provided Iaito Production Certificate with your Iaito.

Iaido teaches the art of using the katana, thus it is traditionally practiced with shinken, or real swords. Many experienced practitioners use shinken, but beginners typically use iaito until they're at least 3-4dan. Thanks to the availability of this safe practice tool, more people enjoy iaido than ever before. Here we'll tell you about what an iaito is, how to choose one, and how to use iaito safely.

Choosing Your Iaito

"Iaito" is what sword that is used for iaido is called. "Mogito", a common name for synthetic practice swords in Japan, can refer to a wide range of synthetic swords. They're also called "iaito" when they're made and used for martial arts practice. Some people will call a shinken/nihonto they use for iaido an "iaito", but nowadays we prefer to call them "iai-yo shinken", literally "shinken for iaido." It's much easier to understand which you're referring to if we use these names.

Japanese swords (shinken), are swords that were made from Japanese iron using techniques rooted in the time-honored smithing arts of Japan. We often say they are "for appreciation", "for iaido", "for battodo", etc based on the customer's intended use but they are all fundamentally the same: shinken.

Iaito blades are cast without using iron. The fact that they're produced in a mold separates them from shinken.

The carrying, transport, of swords in Japan is prohibited by the Swords and Firearms Control Law (1958). However, use of shinken for iaido is permitted as reasonable use as long as the registration card (jyuhotokenrui torokusho) is kept with the sword at all times.

While an iaito, which differs from shinken in both material and production, is not considered a bladed weapon or tool, synthetic blades that are made to look like bladed weapons and tools are also restricted in Japan unless there is reasonable use. (Swords and Firearms Control Law (1958) 22.4)

Iaito are made primarily from zinc alloy. Our shop creates particularly strong blades by sand casting our original mix of metals.

The average iaidoka cannot tell what materials or method was used to make an iaito, so it's best to ask the seller to ensure you have the safest possible iaito to practice with. It's also a good idea to buy your iaito from a trustworthy shop with good follow-up services.

The previous president, Yasuo Igarashi (born 1929) established Nosyudo in the 1970's, and created iaito made for iaido from day one. We'd like to share

what we've learned from our years of experience in selecting iaito with you.

Sand casting uses a mold made out of sand that allows most of the air bubbles to escape through openings in the mold.

On the other hand, compression molding results in the metal hardening with large bubbles trapped inside. Iaito blades made with sand casting are sturdier and safer than blades made using this method.



Nosyudo founder
Yasuo Igarashi

Of course, the quality and safety of an iaito is usually reflected in the cost. Depending on the individual's circumstances and their teacher's requirements, some people focus more on the quality of the iaito and others on the price.

Iaito Blades

The weight of an iaito's blade doesn't affect whether or not it'll break easily, however the quality of the materials used and the shape of the bo-hi are important. Tiny openings and small, unmelted bits of metal also have little effect on the finished blade.

Modern sword blades have become lighter than ever before. While they are thinner, improvements to the production process has resulted in them being more durable.

The reason the bo-hi of most sand cast iaito end before the habaki is to prevent bending.

Choose an Iaito You Like

We get orders from university iaido clubs from all over Japan every year. Freshmen students often order one of our Shoden or Chuden iaito, then upgrade when they're sophomores or juniors. Not only students, but anyone who practices iaido for a while begins to prefer a certain balance or sound and will consult us when they order. Many such customers purchase our highest level Okuden Shinkensaku despite the price and we do

our best to create an iaito to their specifications.

We always aim to provide the safest, easiest to use, well-balanced katana to our customers.

Furthermore, focusing on quality over quantity, custom swords are our specialty and we strive for originality. In addition to regularly improving the materials and shape for our iaito blades, we have a large selection of tsuba, habaki, fuchi & kashira, menuki, hamon, and colors and designs of tsukaito and saya.

The three series of iaito we produce are Shoden, Chuden, and Okuden with the latter split into Nosyusaku or Shinkensaku options. Prices range anywhere from about ¥40,000 to ¥150,000.

This catalog illustrates the wide variety we can produce. Chuden and Okuden iaito have more options for your koshirae as well as optional upgrades. It costs a little extra for these upgrades, but it's possible to make a truly unique sword.

Choosing a Shinken for Iaido

If you wish to use a shinken for iaido someday, you have two options: to order a custom shinken to suit your tastes or to search for a shinken you like. We recommend using the iaito you use regularly as reference. For example, does the length, weight, and tsuka suit you or not?

There are many people who do not know the sword's length, weight, or tsuka length, but it's important to know this information when shopping for a shinken.

The relative density of a shinken is heavier than an iaito. Even if the weight is the same, the width and thickness of the blade will be thinner and narrower than an iaito's. Also, even if the sword is a little heavy, the balance may make it feel light when swung.

The balance and sound of the sword when swung depends greatly on how the bo-hi is carved. A katana with poor balance will feel heavy, but a well-balanced sword will feel light. Carefully evaluate what you want when you think about buying your next iaito or shinken. Keep these in mind and also consult your iaido teachers, seniors, and sword sellers.

Using Your Iaito Safely

One should always keep safety in mind when using an iaito.

It's important to inspect your iaito before iaido practice.

In the worst case scenario, someone could be hurt if your sword breaks. You should at least

check the mekugi, the piece of wood keeps the blade in the tsuka, but the Zen Nihon Kendo Renmei's guide for using iaito for iaido on their home page (JP) recommends you occasionally disassemble, check, and put your own sword back together. You'll become familiar with how your iaito is constructed and confirm whether or not it is sound.

Checking the Mekugi

The most important inspection that you can do yourself is to check whether or not the mekugi is broken or loose. Iaido instructors should have their students check their mekugi before practice. There's no need to hesitate to remind your students.

First, push on the mekugi with your thumb to see if it moves. If it doesn't, it's fine but if it moves even slightly, stop practicing and consult your iaido teacher. Change out your mekugi as soon as possible. You should keep a spare mekugi with you.



Checking the Mekugi

Regular Inspection

We recommend that you take your sword to an iaito shop for regular inspections. Like how a car needs to be inspected regularly, it's good to have a knowledgeable specialist look over your sword to ensure it's safe to use. While you may inspect it regularly yourself, many people, especially beginners, don't know what to look for or how to put a sword back together correctly without damaging it. Furthermore, even if an experienced individual inspects their iaito regularly, there could be weak points or problems forming that aren't obvious. Letting a professional look over your sword could result in such points being fixed before they exacerbate. We ask sensei to please transmit the importance of regular inspections to your students.

For the safety of yourself and those around you, please consider it to be your duty as martial artists to inspect your sword regularly, be it a shinken or iaito. We have provided a "Repair Request Form" at the back of this catalog for you to use if necessary.

In addition, school clubs and dojo can get insurance coverage. If your group isn't insured, we ask that you please consider enrolling in suitable insurance coverage.

Iaito blade fresh out of the sand casting process

It's still very rough, but it will become a new iaito



Blade Preparation

The blade is polished smooth, then plating is applied.



Blade Preparation - Shinken-Hi

Shinken-hi (an option for Okuden Iaito) being carved.



Blade Preparation - Hamon



Engraving the Order Number

Nosyudo engraves the production year and month and the order number onto every blade.



Habaki - Polish

The habaki is carefully polished smooth so it looks nice and is safe.

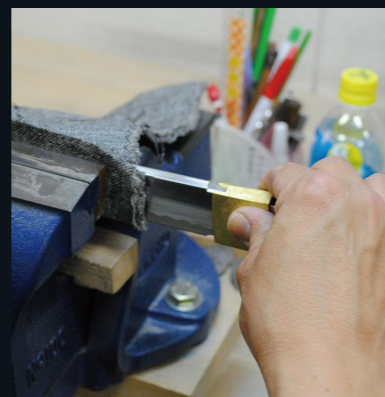

Habaki - Attachment

The habaki is attached tightly to the blade for safety.

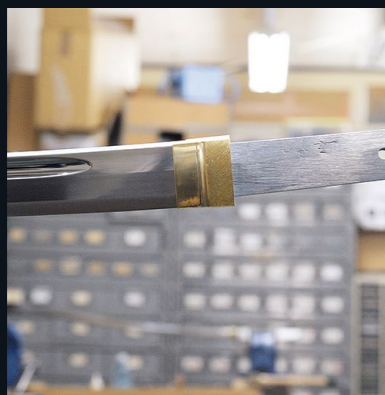

Habaki - Completion

The bo-hi ends before the habaki to preserve the strength of the iaito blade.



Tsuka Base - Gluing Same

Same (ray skin) is glued to the tsuka. It's rough or smooth depending on the direction rubbed.



Tsuka Base - Setting the Same



Tsuka Base - Grip Customization

The tsuka is filed down and completed. We can customize it to fit the customer's hand.



Tsukamaki

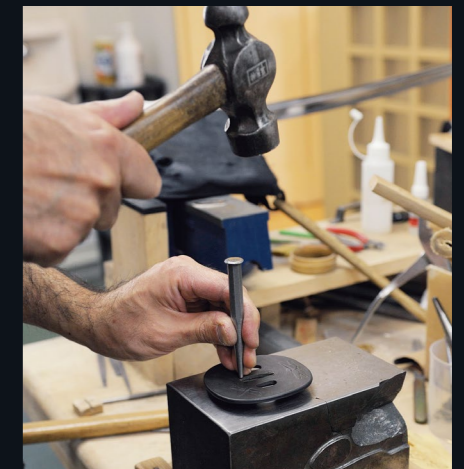

Construction - Tsuba Adjustment

We adjust the fit of the tsuba with a chisel so it fits the nakago (tang) of the blade snugly.



Construction

The blade is secured in a jig, then the tsuka is attached.



Construction - Making the Mekugi-Ana

The hole for the mekugi-take is made after the tsuka is attached.

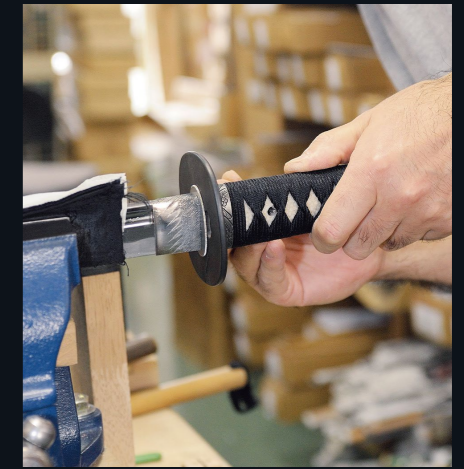

Construction - Mekugi-take Placement

The last step is to place the mekugi-take in the tsuka and the sword is complete.



Inspection

Each sword is carefully inspected and checked against the order form.

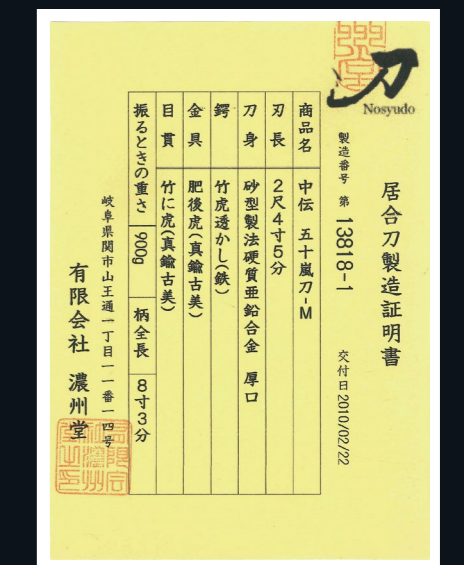

Nosyudo's Iaito Certificate. The user's manual is on the back.

Shoden Iaito

Thick Blade: No.10 / Thin Blade: No.20

For
Beginners

A good sword to for a solid start.
We can customize it to suit your height, age, and gender.



Tsuba



T-3 Higo 105g 78.5x72.5x3.9(mm)
T-4 Musashi 85g 76x80.5x3.9(mm)
T-100 Shiho Sukashi 85g 78.0x75.5x3.9(mm)

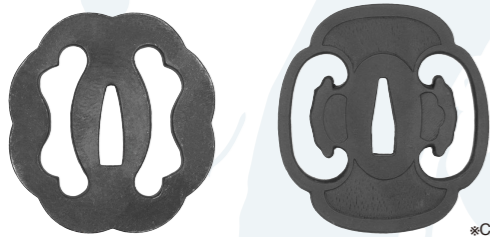

T-134 Yatsumokko 90g 74.0x70.0x3.9(mm)
T-149 Mokko 135g 84.0x77.0x4.5(mm)
*Can't add plating



*Shitodome can be added for a fee.

Menuki



MY-60 Butterflies (aged brass)

Fuchi Kashira



KY-2 Vines (aged brass)
39mm/40mm/41mm

Shoden Youth Edition No.30



Tsuba



T-1 Efugo Sukashi (L)78.0x78.0x3.9(mm) 90g (S)70.5x71.0x3.9(mm) 70g
T-152 Shihomokko 110g 76.0x68.5x3.8(mm)



T-150 Nanakoji 120g 75.0x70.5x4.2(mm)
T-151 Tsurumaru (L)81.0x81.0x4.9(mm) 85g (S)75.0x75.0x4.6(mm) 80g
*Can't add plating



Menuki



MY-67 Bamboo (aged brass)

Fuchi Kashira



KY-1 Rope (aged brass)
37.5mm/39mm

Production time: 1-1.5 months minimum

The gold mark indicates customizable parts.

Fuchi•Kashira

Vines (aged brass)
Fuchi•Kashira
*Not customizable

Tsuba

Higo, Musashi, Shiho Sukashi, Yatsumokko, or Mokko
*Can choose tsuba on P31-34 +Fee
*Aged brass and aged silver plating are options +Fee
*Customer-provided cannot be used

Blade Length (shaku.sun.bu)

Thick: 2.2.5 - 2.7.0
Thin: 2.2.0 - 2.5.5
*Blades 2.5.0 and longer cost extra

Menuki

Butterflies (aged brass)
*Can choose menuki on P29-30 +Fee
*Can use customer-provided (w/ restrictions)

Position - Standard
*Reverse, center are options

Seppa

Brass
*Not customizable

Habaki

Plain brass
*Not customizable

Bo-Hi

Included
*No bo-hi is an option +Fee
Bo-hi stops before the habaki

Hamon

Notare
*Can choose from HM-01 - HM-04 (P19)
*Can choose Revival Series Hamon

Tsuka Color

Black, steel blue, or azuki
*Changes OK +Fee

Tsukamaki | Hinerimaki

Tsukaito | Cotton or silk

Same

Cotton: white plastic same
Silk: white same
*Can upgrade to same +Fee
*Can change same color +Fee

Kurigata

No shitodome
*Can add shitodome +Fee

Kurigata Position

Up to 2.3.0 long: 6.5cm from koikuchi
From 2.3.5 long: 7.5cm from koikuchi
*Changes OK +Fee

Saya Finish

Black gloss, black stone, or brown stone
*Can choose saya finishes on P37-39 +Fee

Metal Kojiri

None
*Metal kojiri is not an option

Production time: 1-1.5 months minimum

The gold mark indicates customizable parts.

Fuchi•Kashira

Rope (aged brass)
*Not customizable

Tsuba

Efugo Sukashi, Shihomokko, Nanakoji, or Tsurumaru
*Cannot choose tsuba on P31-34
*Aged brass and aged silver plating are options +Fee
*Customer-provided cannot be used

Blade Length (shaku.sun.bu)

Thin: 2.2.0 - 2.4.5
Narrow: 1.8.0 - 2.3.0

Menuki

Bamboo (aged brass)
*Can choose menuki on P29-30 +Fee
*Customer-provided cannot be used

Position - Standard
*Reverse, center are options

Seppa

Brass
*Not customizable

Habaki

Plain brass
*Not customizable

Bo-Hi

Included
*No bo-hi is an option +Fee
Bo-hi stops before the habaki

Hamon

Suguha
*Can change to Notare
*Revival Series Hamon are not options

Tsuka Color

Black, steel blue, or azuki
*Changes OK +Fee

Tsukamaki | Hinerimaki

Tsukaito | Cotton

Same

White plastic same
*Can upgrade to same +Fee
*Can change same color +Fee

Kurigata

No shitodome
*Can add shitodome +Fee

Kurigata Position

Up to 2.3.0 long: 6.5cm from koikuchi
From 2.3.5 long: 7.5cm from koikuchi
*Changes OK +Fee

Saya Finish

Black stone or brown stone
*Can choose saya finishes on P37-39 +Fee
*Black gloss is +¥1,100 +Fee

Metal Kojiri

None
*Metal kojiri is not an option

Chuden Igarashito

A practical, no-frills iaito with a lot of options.
Create an original iaito just for you.

Practical Sand Cast Alloy Blade • Thin Edge • High-End Construction



- Every Chuden iaito is made to order so we can meet our customers' requests. (Wooden parts are premade)
- Please select from our 3 blade types based on your age, build, and gender.
- Please contact us about any customizations not listed below.

Production Time 1.5-2 months ※Production time may be longer depending on your order

For a solid swing sound Please choose add the Select Blade option ※+¥2,200

Production time: 1.5-2 months minimum

The gold mark indicates customizable parts.

Fuchi • Kashira

Aged brass (Choose from P26-28)
We suggest 40mm+ for men and 40mm- for women
※Can upgrade to silver **+Fee**
※Can use customer-provided (w/ restrictions)

Menuki

Aged brass (Choose from P29-30)
※Can upgrade to silver **+Fee**
※Customer-provided can be used (w/ restrictions)

Position - Standard
※Reverse, center are options

Tsuba

Choose from catalog (P31-34)
※Aged brass, aged silver plating are options **+Fee**
※Can use customer-provided (w/ restrictions, fees for semegane) **+Fee**

Seppa

Brass
※Changes OK **+Fee**

Habaki

Plain brass
※Changes OK **+Fee**

Bo-Hi

Included
※No bo-hi is an option **+Fee**
Bo-hi stops before the habaki

Hamon

Choose from HM01-HM04 (P19)
※Revival Series Hamon are options **+Fee**
※We can't do large hamon on narrow blades

Blade Length (shaku.sun.bu)

Thick: 2.2.5 - 2.7.0
Thin: 2.2.0 - 2.5.5
Narrow: 1.8.0 - 2.3.0
※Blades 2.5.0 and longer cost extra **+Fee**
※Blades shorter than 2.2.0 charged suriage fee **+Fee**
※Blades 1.5.3 - 1.8.0 available for Okuden only

Tsuka Color

Choose from catalog (P35-36)
※Cannot use customer-provided

Tsukamaki

Hinerimaki
※Changes OK **+Fee**

Tsukaito Cotton, silk, or leather

Same White same

※Same color can be changed **+Fee**

Kurigata

No shitodome
※Changes OK **+Fee**

Kurigata Position

Up to 2.3.0 long: 6.5cm from koikuchi
From 2.3.5 long: 7.5cm from koikuchi
※Changes OK **+Fee**

Saya Finish

Black gloss, black stone, or brown stone
※Can choose saya finishes on P37-39 **+Fee**

Metal Kojiri

None
※Can add metal kojiri **+Fee**

※See P21 for information on tsuka length. ※Minor flaws such as color spots and tiny holes are a natural part of the production process.

Add-on Fees Base costs

Select Blade	¥2,200	Same color changes: Black, Antique, etc	¥2,200~
Tsuba	Aged brass plating	Oyasame	¥8,800
	Aged silver plating	Fuchi kashira silver upgrade	¥11,000
	※Plating is rust resistant	Menuki silver upgrade	¥5,500
Revival Hamon Series	¥2,200	Alternative tsukamaki	¥5,500~

Sample Tsuba, Fuchi • Kashira, Menuki Sets

Hijikata Set

Tsuba T-60 Hijikata 135g
76.5×69.5×4.6(mm)

Fuchi Kashira KY-42 Hijikata
40mm

Menuki MY-55 Japanese Pepper



Kakotsuruhe Set

Tsuba T-36 Yagyū 90g
73.0×73.0×4.3(mm)

Fuchi Kashira KY-51 Yagyū Wave
40mm/41mm

Menuki MY-73 Kakotsuruhe



Hideyoshi Set

Tsuba T-49 Paulownia (Hideyoshi) 95g
75.0×71.5×4.9(mm)

Fuchi Kashira KY-29 Paulownia (Hideyoshi)
38.5mm

Menuki MY-9 Triple Paulownia



Kusunoki Set

Tsuba T-65 Sakura Kiku Sukashi 95g
71.5×71.5×4.0(mm)

Fuchi Kashira KY-48 Kikusui
40mm/41mm

Menuki MY-20 Single Kiku



Nobunaga Set

Tsuba T-127 Old Coins 135g
76.0×76.5×3.8(mm)

Fuchi Kashira KY-113 Old Coins
41.5mm

Menuki MY-70 Old Coins



Musashi Set

Tsuba T-95 Miyamoto Musashi 85g
77.5×67.5×4.6(mm)

Fuchi Kashira KY-46 Musashi
41mm

Menuki MY-11 Bee



Katsujin Ken Set

Tsuba T-99 Katsujin Ken 130g
77.0×70.5×4.2(mm)

Fuchi Kashira KY-79 Katsujin Ken
41mm

Menuki MY-84 Katsujin Ken



Kanetsugu Set

Tsuba T-137 Ai (Kanetsugu) 105g
75.5×71.5×3.9(mm)

Fuchi Kashira KY-120 Ai (Kanetsugu)
41mm

Menuki MY-97 Aizen Myo-o



Ryoma Set

Tsuba T-96 Rankanzu 85g
77.0×75.0×3.5(mm)

Fuchi Kashira KY-102 Awa
40mm

Menuki MY-49 Rain Dragon



Tsuba T-8 Scaled Dragon 110g
73.5×70.0×4.9(mm)

Fuchi Kashira KY-4 Dragon
39mm/41.5mm

Menuki MY-98 Twisted Mino Dragon



Tsuba T-16 Wave & Koi 120g
76.5×69.0×3.7(mm)

Fuchi Kashira KY-8 Wave
40mm

Menuki MY-41 Wave & Koi



Tsuba T-19 Bird 125g
80.5×75.0×3.3(mm)

Fuchi Kashira KY-9 Bird
40.5mm

Menuki MY-58 Plover



For Kendo Kata Sand Cast Zinc Alloy Blade • Thick Edge

For Kendo Kata Daito (2.3.5)

Hamon: Notare **Tsuba:** Efugo Sukashi (iron)

Tsuka: Black cotton hinerimaki (length 8.3)

Fuchi Kashira: Rope (aged brass)

Menuki: Butterflies (aged brass) **Saya:** Black Stone

※Can make 2.2.5 - 2.7.0 long. (fee for blades over 2.5.0)

※Everything except fuchi kashira are customizable (fees may be applied)

For Kendo Kata Shoto (1.5.0)

Hamon: Notare **Tsuba:** Efugo Sukashi (iron)

Tsuka: Black cotton hinerimaki (length 5.5)

Fuchi Kashira: Rope (aged brass)

Menuki: Butterflies (aged brass) **Saya:** Black Stone

※Can make 1.3.5 - 1.5.2 long (suriage fee for blades up to 1.4.5)

※Everything except fuchi kashira are customizable (fees may be applied)



Chuden For Kendo Kata

Hamon, tsuba, fuchi kashira, menuki, saya can all be selected from this catalog

※Daito: 2.2.5 - 2.7.0 (fee for blades 2.5.0 and longer)

※Shoto: 1.3.5 - 1.5.2 (suriage fee for blades up to 1.4.5)

Okuden Nosyusaku

For those who want the feel of a real sword.
Each is a masterpiece with the air of famous swords from the past.

Authentic Sand Cast Alloy Blade • Thin edge • Constructed by Craftsmen



- Every Okuden Nosyusaku iaito is made to order so we can meet our customers' requests.
- Please select from our 3 blade types based on your age, build, and gender.
- Please contact us about any customizations not listed below.

Production Time 3.5-4 months ※Production time may be longer depending on your order

Recommendation We recommend our aged brass anti-rust tsuba plating. ※+¥6,600

※The bo-hi ends before the habaki to strengthen the blade

Two habaki options

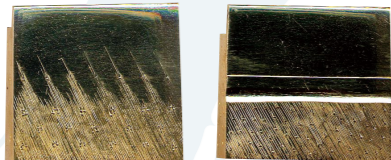

Brass/Yujo Brass/Shonai

Includes metal kojiri



※Can be made without metal kojiri
※Kuwagata kojiri cost an additional +¥5,500

Choose Koshirae DX to have a shinken sayashi make the tsuka and saya base by hand. +Fee

The gold mark indicates customizable parts.

Fuchi • Kashira

- Aged brass (Choose from P26-28)
- We suggest 40mm+ for men and 40mm- for women
- ※Can upgrade to silver +Fee
- ※Can use customer-provided (w/ restrictions)

Menuki

- Aged brass (Choose from P29-30)
- ※Can upgrade to silver +Fee
- ※Can use customer-provided (w/ restrictions)
- Position - Standard
- ※Reverse, center are options

Tsuba

- Choose from catalog (P31-34)
- ※Aged brass, aged silver plating are options +Fee
- ※Can use customer-provided (w/ restrictions, fees for sekigane) +Fee

Seppa

- Gold plated
- ※Changes OK +Fee

Habaki

- Brass Yujo or Brass Shonai
- ※Changes OK +Fee

Bo-Hi

- Included (up to 2.7.0)
- ※No bo-hi is an option +Fee
- Bo-hi stops before the habaki

Hamon

- Choose from our 11 options (P19)
- ※Revival Series Hamon are included
- ※We can't do large hamon on narrow blades
- ※Suguha is the only option for 2.7.1 and longer

Blade Length (shaku.sun.bu)

- Thick: 2.2.5 - 3.3.0*
- Thin: 2.2.0 - 2.5.5
- Narrow: 1.8.0 - 2.3.0
- ※Blades 2.5.0 and longer cost extra +Fee
- ※Blades shorter than 2.2.0 charged suriage fee +Fee

Tsuka Color

- Choose from catalog (P35-36)
- ※Customer-provided negotiable

Tsukamaki

- Hinerimaki
- ※Changes OK +Fee

Tsukaito

- Silk or leather
- ※Cotton is an option

Same

- White same
- ※Same color can be changed +Fee

Kurigata

- No shitodome
- ※Changes OK +Fee

Kurigata Position

- Up to 2.3.0 long: 6.5cm from koikuchi
- From 2.3.5 long: 7.5cm from koikuchi
- From 2.8.0 long: 9.0cm from koikuchi
- ※Changes OK +Fee

Saya Finish

- Black gloss, black stone, or brown stone
- ※Can choose saya finishes on P37-39 +Fee

Metal Kojiri

- Included
- ※w/out metal kojiri is an option

※ Small holes and raised patches in the chrome may occur in blades over 2.6.1 long. Please pardon spots that are smaller than 3mm.
※ Minor flaws such as color spots and tiny holes are a natural part of the production process.

Okuden Shinkensaku

Our finest iaito created with skills polished by history and tradition. Perfect for iaidoka who demand a practice sword with the look and feel of a shinken.

Top Quality Sand Cast Alloy Blade • Thin Edge • Constructed by Craftsmen

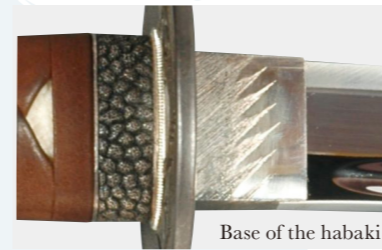

- Every Okuden Nosyusaku iaito is made to order so we can meet our customers' requests.
- Please select from our 3 blade types based on your age, build, and gender.
- Please contact us about any customizations not listed below.

Production Time 3.5-4 months ※Production time may be longer depending on your order

Recommendation We recommend our aged silver anti-rust tsuba plating. ※+¥6,600

※The bo-hi ends before the habaki to strengthen the blade

Two habaki options

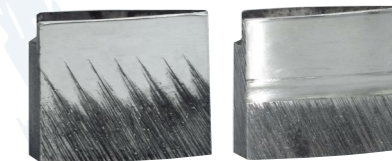

Silver/Yujo Silver/Shonai

Includes metal kojiri



※Can be made without metal kojiri
※Kuwagata kojiri cost an additional +¥5,500

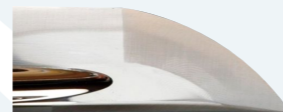

Kakidome-Hi (Shoden, Chuden, Okuden) Standard



Okuden Shinkensaku Limited Shinken-Hi (+¥6,600)

Choose Koshirae DX to have a shinken sayashi make the tsuka and saya base by hand. +Fee

The gold mark indicates customizable parts.

Fuchi • Kashira

- Silver (Choose from P26-28)
- We suggest 40mm+ for men and 40mm- for women
- ※Aged brass is an option
- ※Can use customer-provided (w/ restrictions)

Menuki

- Silver (Choose from P29-30)
- ※Aged brass is an option
- ※Can use customer-provided (w/ restrictions)
- Position - Standard
- ※Reverse, center are options

Tsuba

- Choose from catalog (P31-34)
- ※Aged brass, aged silver plating are options +Fee
- ※Can use customer-provided (w/ restrictions, fees for sekigane) +Fee

Seppa

- Silver plated
- ※Changes OK

Habaki

- Silver Yujo or Silver Shonai
- ※Changes OK +Fee

Bo-Hi

- Included (up to 2.7.0)
- ※No bo-hi is an option +Fee
- ※Shinken-hi is an option +Fee
- Bo-hi stops before the habaki

Hamon

- Choose from our 11 options (P19)
- ※Revival Series Hamon are included
- ※We can't do large hamon on narrow blades
- ※Suguha is the only option for 2.7.1 and longer

Blade Length (shaku.sun.bu)

- Thick: 2.2.5 - 3.3.0*
- Thin: 2.2.0 - 2.5.5
- Narrow: 1.8.0 - 2.3.0
- ※Blades 2.5.0 and longer cost extra +Fee
- ※Blades shorter than 2.2.0 charged suriage fee +Fee

Tsuka Color

- Choose from catalog (P35-36)
- ※Customer-provided negotiable

Tsukamaki

- Hinerimaki
- ※Changes OK +Fee

Tsukaito

- Silk or leather
- ※Cotton is an option

Same

- White same
- ※Same color can be changed +Fee

Kurigata

- No shitodome
- ※Changes OK +Fee

Kurigata Position

- Up to 2.3.0 long: 6.5cm from koikuchi
- From 2.3.5 long: 7.5cm from koikuchi
- From 2.8.0 long: 9.0cm from koikuchi
- ※Changes OK +Fee

Saya Finish

- Black gloss, black stone, or brown stone
- ※Saya finishes on P37-39 are options +Fee

Metal Kojiri

- Included
- ※w/out metal kojiri is an option

※ Small holes and raised patches in the chrome may occur in blades over 2.6.1 long. Please pardon spots that are smaller than 3mm.
※ Minor flaws such as color spots and tiny holes are a natural part of the production process.

Revival Series: Famous Swords

Each of these iaito are made to look like famous swords by Kanesada, Masamune, Muramasa, and more

We used the works of generations of famous sword smiths as a concept and researched koshirae from appropriate periods to create this series. These swords are made to the same standards as our Chuden Igarashito iaito and can be used for iaido practice.

※We can use these as a base and customize the length, tsuka color, and fittings.

Aizu Kanesada Utsushi

Active during the Bakumatsu, the Aizu Kanesada line is among of the later generations of the Kanesadas that begun Seki. They were famous smiths retained by Aizu Province. Many Shinsengumi members, including the famous Hijikata Toshizo, favored Kanesada swords.



Blade Length	2.3.9
Hamon	HM-A Kanesada
Habaki	Plain Brass
Tsuba	T-112 Butterflies (iron)
Tsuka	TS-09 Navy Blue Silk Hinerimaki(white same)
Tsuka Length	8.3
Fuchi Kashira	KY-21 Peony Karakusa (aged brass)
Menuki	MY-60 Butterflies (aged brass)
Saya	SY-03 Brown Stone
Silk Sageo	Navy Blue (decorative knot)
Price	¥76,000

Nio Kiyotsuna Utsushi

The first generation of the Nio Ichimon line of smiths that were active in Suo Province from the Kamakura to the Muromachi period. At the Battle of Sugimori, Kiyotsuna used his own sword to cut the chains of the statue of Nio at the burning temple, Nio-do, saving it from the fire.



Blade Length	2.4.0
Hamon	HM-D Kunimitsu
Habaki	Plain Brass
Tsuba	T-78 Owari (iron)
Tsuka	TS-13 White Silk Hinerimaki (black same)
Tsuka Length	8.3
Fuchi Kashira	KY-32 Tensho (aged brass)
Menuki	MY-78 Mino Kiku (aged brass)
Saya	SY-01 Black Gloss
Silk Sageo	White (decorative knot)
Price	¥78,000

Nagasone Kotetsu Utsushi

Nagasone Kotetsu, a famous smith who changed craft from armorer to swordsmith. In his day, his works were famed for their unique design and sharpness. Kondo Isami, the commander of the Shinsengumi, favored this sword. It was 2.4.4 shaku long at the time it was used during the Ikedaya Incident.



Blade Length	2.4.4
Hamon	HM-G Kotetsu
Habaki	Plain Brass
Tsuba	T-21 Dragonfly (iron)
Tsuka	TS-01 Black Silk Katatemaki (black same)※center menuki
Tsuka Length	8.3
Fuchi Kashira	KY-48 Kikusui (aged brass)
Menuki	MY-83 Wave & Maple (aged brass)
Saya	SY-02 Black Stone
Silk Sageo	Black (decorative knot)
Price	¥84,000

Seshu Muramasa Utsushi

Seshu Muramasa is a famous line of smiths in Kuwana in modern Mie Prefecture that continued for three generations from the Muromachi to the Edo era. The hakomidare hamon is one of their identifying features. Their works were avoided because the Tokugawa thought they were cursed blades, but were loved by followers of the emperor during the Bakumatsu.



Blade Length	2.3.7
Hamon	HM-E Muramasa
Habaki	Plain Brass
Tsuba	T-46 Sanskrit (iron)
Tsuka	TS-07 Light Steel Blue Silk Hinerimaki(white same)
Tsuka Length	8.3
Fuchi Kashira	KY-84 Aoi Karakusa
Menuki	MY-51 Marishiten
Saya	SY-02 Black Stone
Silk Sageo	Light Steel Blue (decorative knot)
Price	¥76,000

Soshu Masamune Utsushi

A famous smith who was active Kamakura in modern Kanagawa Prefecture who made many famous swords during the Kamakura period. Many of his works are now national treasures or important cultural properties. Many blades he made were shortened, but many tanto remain.



Blade Length	2.3.4
Hamon	HM-C Masamune
Habaki	Plain Brass
Tsuba	T-28 Wave & Plover (iron)
Tsuka	TS-01 Black Silk Hinerimaki (white same)
Tsuka Length	7.9
Fuchi Kashira	KY-18 High Wave (Aged Brass)
Menuki	MY-98 Twisted Mino Dragon
Saya	SY-02 Black Stone
Silk Sageo	Black (decorative knot)
Price	¥76,000

Suishinshi Masahide Utsushi

Suishinshi Masahide was known for his studies of the various schools of sword smithing and his efforts to revive old methods to make shinshinto. Many students of the sword used his blades. Katsu Kaishu is also known to have treasured his sword that was made by this smith.



Blade Length	2.3.5
Hamon	HM-F Sukehiro
Habaki	Plain Brass
Tsuba	T-106 Praying Mantis (iron)
Tsuka	TS-15 Rouge Silk Hinerimaki (black same)
Tsuka Length	8.3
Fuchi Kashira	KY-86 Wicker (aged brass)
Menuki	MY-22 Dragonfly (aged brass)
Saya	SY-02 Black Stone
Silk Sageo	Rouge (decorative knot)
Price	¥78,000

Magoroku Kanemoto Utsushi

Magoroku Kanemoto is one of the most famous swordsmiths from Seki. Of all the Kanemotos that have been active from the Muromachi period to now, the second generation Magoroku Kanemoto is the especially noted. His swords were held in high esteem by Takeda Shingen, Toyotomi Hideyoshi, and many others.



Blade Length	2.3.8
Hamon	HM-B Kanemoto
Habaki	Plain Brass
Tsuba	T-15 Tiger & Bamboo (iron)
Tsuka	TS-02 Antique Black Silk Hinerimaki (black same)
Tsuka Length	8.3
Fuchi Kashira	KY-49 Basket (aged brass)
Menuki	MY-40 Tiger & Bamboo (aged brass)
Saya	SY-02 Black Stone
Silk Sageo	Antique Black (decorative knot)
Price	¥78,000

Revival Series: Famous Shogun

From Oda Nobunaga to the master swordsman Miyamoto Musashi, this series features the swords of famous historical figures.

Every sword is made to the same standards as our Okuden Nosyusaku iaito and can be used for iaido practice. The bo-hi is carved so they make an especially hearty sound when swung.

Oda Nobunaga

The first unifier of Japan, Oda Nobunaga. He was assassinated by Akechi Mitsuhide in 1582 in the Honno-ji Incident just as he was on the verge of unifying the country under military might. He favored flashy hamon and collected over 20 Mitsutada swords.



Blade Length	2.4.0
Hamon	HM2-H Bizen Osafune Ju Mitsutada (double)
Habaki	Brass Yujo
Tsuba	T-127 Old Coins (iron)
Tsuka	TS-09 Antique Steel
Tsuka Length	8.3
Fuchi Kashira	KY-113 Old Coins (aged brass)
Menuki	MY-70 Old Coins (aged brass)
Saya	SY-45 Dark Rouge Gloss
Silk Sageo	Antique Steel (decorative knot)
Price	¥113,000

Naoe Kanetsugu

Naoe Kanetsugu was a swordsman who followed the path of love (ai) and justice (gi) and was famous for his loyalty to Uesugi Kagekatsu. The tale of a time when his beloved sword, Suijingiri Kanemitsu, was used to strike down the water god and subdue a flood is still told today.



Blade Length	2.3.5
Hamon	HM2-H Bizen Osafune Ju Kanemitsu (double)
Habaki	Brass Yujo
Tsuba	T-137 Ai (Kanetsugu) (iron)
Tsuka	TS-01 Black Silk Hinerimaki (black same)
Tsuka Length	8.3
Fuchi Kashira	KY-120 Ai (Kanetsugu) (aged brass)
Menuki	MY-97 Aizen Myo-o (aged brass)
Saya	SY-01 Black Gloss
Silk Sageo	Black (decorative knot)
Price	¥108,000

Kusunoki Masashige

Kusunoki Masashige was the general of Kawachi. He was famed for his work alongside Ashikaga Takauji to overthrow Retired Emperor Go-Daigo's Kamakura Bakufu from the end of the Kamakura era to the Nanbokucho era.



Blade Length	2.4.0
Hamon	HM2-K Bizen Osafune Ju Kagemitsu (double)
Habaki	Brass Yujo
Tsuba	T-107 Tadatoki Kiku
Tsuka	TS-05 Steel Blue Silk Hinerimaki (white same)
Tsuka Length	8.3
Fuchi Kashira	KY-48 Kikusui (aged brass)
Menuki	MY-20 Single Kiku
Saya	SY-01 Black Gloss
Silk Sageo	Steel Blue (decorative knot)
Price	¥106,000

Miyamoto Musashi

The great master swordsman who is renowned for his victory in over 60 swordfights. In addition to establishing the double sword style, Niten Ichi Ryu, he was also known for his ink paintings and other arts. We recreated the "Musashi Koshirae" that was made by Musashi himself.



Blade Length	2.3.5
Hamon	HM2-L Izuminokami Kaneshige (double)
Habaki	Brass Yujo
Tsuba	T-95 Miyamoto Musashi (iron)
Tsuka	TS-02 Antique Black Silk Hinerimaki (black same)
Tsuka Length	8.3
Fuchi Kashira	KY-46 Musashi (aged brass)
Menuki	MY-31 Gourd & Catfish
Saya	SY-44 Wine Gloss
Silk Sageo	Antique Black (decorative knot)
Price	¥115,000

Yagyū Toshikane

Being the son of the kenjutsu instructor for Owari han, Yagyū Toshikane learned swordsmanship from a young age and became known as "The Prodigy of Owari". He not only became the instructor for Tokugawa Mitsutomo at the age of 24, but also completed the creation of Yagyū Shinkage Ryu Kenjutsu alongside the founder. His sword, Fuchingiri Mitsuyo, is famous.



Blade Length	2.3.5
Hamon	HM2-M Hatamitsuyo (double)
Habaki	Brass Yujo
Tsuba	T-36 Yagyū (iron)
Tsuka	TS-03 Azuki Silk Hinerimaki (white same)
Tsuka Length	8.3
Fuchi Kashira	KY-51 Yagyū Wave (aged brass)
Menuki	MY-73 Kakotsuruhe (aged brass)
Saya	SY-39 Sendan Kizami Dark Brown Gloss
Silk Sageo	Azuki (decorative knot)
Price	¥132,000

Hijikata Toshizo

Hijikata Toshizo, the famed "Demon Vice-Commander" of the Shinsengumi, founded the group along side famous members such as Kondo Isami and Okita Soji. He fought on the side of the shogunate during the Boshin War with his prized sword, made by the 11th generation Aizu Izuminokami Kanesada.



Blade Length	2.3.5
Hamon	HM2-A Izuminokami Kanesada (double)
Habaki	Brass Yujo
Tsuba	T-60 Hijikata
Tsuka	TS-02 Antique Black Silk Hinerimaki (white same)
Tsuka Length	8.3
Fuchi Kashira	KY-42 Hijikata (aged brass)
Menuki	MY-55 Japanese Pepper
Saya	SY-05 Brown Stone Gloss
Silk Sageo	Antique Black (decorative knot)
Price	¥112,000

Sakamoto Ryoma

Sakamoto Ryoma abandoned his domain of Tosa to join the Satcho Alliance and was a major player in the overthrow of the Bakumatsu and the Meiji Restoration. It was reported that he had the Sakamoto family sword, Mutsunokami Yoshiyuki, when he was assassinated at the Omiya Inn in Kyoto.



Blade Length	2.4.0
Hamon	HM2-N Mutsunokami Yoshiyuki (double)
Habaki	Brass Shonai
Tsuba	T-96 Rankanzu (iron)
Tsuka	TS-02 Antique Black Silk Hinerimaki (white same)
Tsuka Length	8.3
Fuchi Kashira	KY-102 Awa (aged brass) *w/kojiri
Menuki	MY-49 Rain Dragon (aged brass)
Saya	SY-03 Brown Stone
Silk Sageo	Antique Black (decorative knot)
Price	¥122,000

Our basic hamon are single hamon (without nie). Double hamon (with nie) are also available. Please let us know which you'd like when you order.

※+¥1,100

互の目 HM-01 GUNOME



直刃 HM-02 SUGUHA



湾れ HM-03 NOTARE

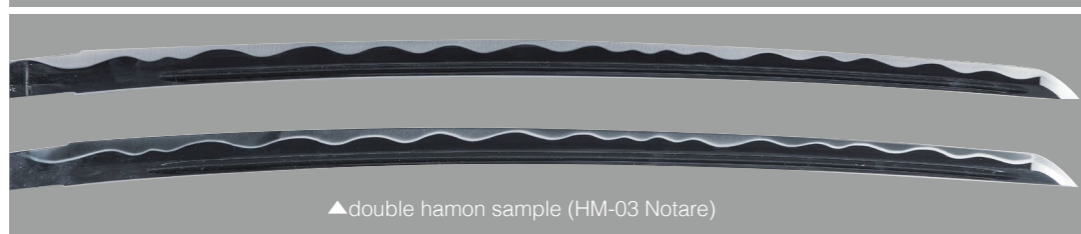

乱れ HM-04 MIDARE



Revival Hamon

The following hamon are based on the hamon used by famous swordsmiths. These cost an additional ¥2,200 for Chuden orders and are included in the price of our Okuden Series.

兼定写し HM-A KANESADA

Aizu Kanesada's signature gunome hamon.



兼元写し HM-B KANEMOTO

A dynamic, pointy gunome hamon that is known as sanbonsugi.



正宗写し HM-C MASAMUNE

The hamon that the first generation Masamune was known for.

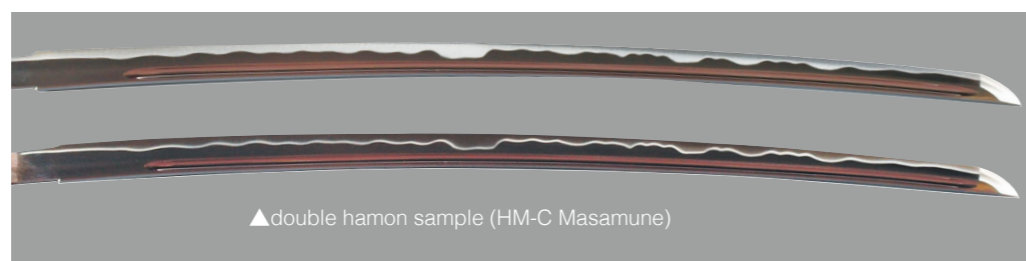

国光写し(清綱) HM-D KUNIMITSU

A particularly sharp and narrow suguha hamon.



村正写し HM-E MURAMASA

Muramasa's unique gunome hamon, hakomidare.



助廣写し(水心子) HM-F SUKEHIRO

The flashy hamon of Osaka Shinto, toranba.



虎徹写し HM-G KOTETSU

A revival of the famous Edo swordsmith Kotetsu's gunome hamon.



※Please understand that each hamon is done by hand by our craftsmen. Results may differ from the photo.

※Double hamon cost an additional ¥1,100. ※We cannot put a wide hamon on narrow blades.

※See P15-16 for more information on our Revival Series: Famous Swords

Standard Length

The first thing you need to consider when you choose an iaito is how it will be used.

Keep in mind your height, arm span, gender, age, the group you practice with, and your style of iaido. Based on that info, you can choose your iaito's length and weight. Make sure you also get advice from your sensei and your seniors at your dojo.

While it's easy to tell you what you should consider when choosing a sword length, it's much harder for a beginner to understand what will suit them. That's why we've created some charts using our years of experience helping new iaidoka select iaito as a starting point to help you choose yours. The one on this page gives suggested lengths based on your gender and height and you can find a chart explaining the weights of each blade type depending on their length on the next page.

We also have a formula to calculate appropriate sword lengths called the Koyama formula. It's height×0.43. This uses centimeters, so you need to divide the total by 30.3 for the length in Japanese shaku.

EX For a 170cm tall man
 $170 \times 0.43 \div 30.3 = 2.41$ (shaku)

*According to this formula, a 2.4.1 long blade is appropriate

*Women should subtract 5bu, making 2.3.6 an appropriate length.

Of course, this can still vary person to person.

Most people of Japanese descent have the an arm span that matches their height, but if your arm span is longer than your height, it may be better to use that instead.

One of the reasons sword length varies by iaido style is that different styles do noto differently. For example, Muso Shinden Ryu does yokonoto, but Muso Jikiden Eishin Ryu does tatenoto. Because of this, Muso Shinden Ryu practitioners' swords are often 5bu to 1sun longer.

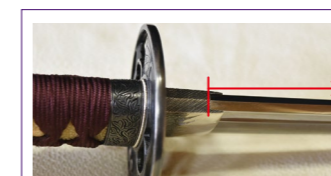

Blade length is measured from the notch on the back of the blade to the tip.

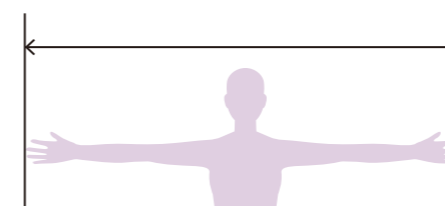

Men's Height(cm)	Sword Length (1sun=approx3.03cm)	Women's Height(cm)
115 - 120	1.8.0 - 1.9.0	120 - 125
120 - 125	1.9.0 - 1.9.5	125 - 130
125 - 130	1.9.5 - 2.0.0	130 - 135
130 - 135	2.0.0 - 2.0.5	135 - 140
135 - 140	2.0.5 - 2.1.0	140 - 145
140 - 145	2.1.0 - 2.1.5	145 - 150
145 - 150	2.1.5 - 2.2.0	150 - 155
150 - 155	2.2.0 - 2.2.5	155 - 160
155 - 160	2.2.5 - 2.3.0	160 - 165
160 - 165	2.3.0 - 2.3.5	165 - 170
165 - 170	2.3.5 - 2.4.0	170 - 175
170 - 175	2.4.0 - 2.4.5	175 - 180
175 - 180	2.4.5 - 2.5.0	180 - 185
180 - 185	2.5.0 - 2.6.5	

(shaku.sun.bu)

Weight

It was once thought that because nihonto are heavy iaito also must be heavy, but now it's more common to select an iaito that fits the user.

The majority of our male customers favor thick blades and ladies thin blades, but there are exceptions. Men with shoulder problems come to our shop and order thin blades and there are women who train hard who choose thick blades.

Longer blades will of course be heavier than shorter ones. We have a chart on the next page showing the estimated weight range of our blades. If you already have one of our iaito, please weigh it without the saya. One way to choose the weight of your new iaito is based on how you feel about the weight your current one. Is it too heavy? Too light? Or is it just right?

Warriors of old who used their swords on the battlefield chose the length, weight, and depth of sori based on how they fought. Also, these factors changed throughout history, resulting in a large variation in the shapes of Japanese swords.

*Iaito weight chart on next page.

Standard Weight Without Saya

The chart below uses brass fuchi, kashira, and menuki with a 100g tsuba with standard tsuka lengths as a base. The weight is different for silver fittings, leather tsukamaki, or a customized Okuden iaito, etc, so please contact us about weight for non-standard options.

Length (shaku.sun.bu)	Thick Blade	Thin Blade	Narrow Blade
1.8.0 - 1.9.0	ask	ask	500 - 550
2.0.0 - 2.2.0	ask	ask	570 - 620
2.2.0	ask	700 - 720	ask
2.2.5	820 - 840	720 - 740	ask
2.3.0	830 - 860	740 - 760	ask
2.3.5	840 - 880	750 - 770	
2.4.0	860 - 900	760 - 780	
2.4.5	880 - 940	770 - 790	
2.5.0	900 - 960	780 - 800	
2.5.5	940 - 990	800 - 820	
2.6.0	960 - 1010		
2.6.5	980 - 1030		
2.7.0	1000 - 1050		

(weight in g)

※We charge an additional ¥2,200 to make swords outside these weight specifications

Selecting Koshirae

We have both hand made and ready-made wood fittings. Depending on the skill of the craftsman, the quality, functionality, and price can vary.

It's possible to wind up with a final product that is poorly balanced even if the koshirae are beautifully made.

The shape of the tsuka is particularly important when making koshirae for iaido. It's important to test out and compare different shapes to see what suits you.

Tsuba

The tsuba functions not only as a guard to keep you from getting cut, but is also an important factor in the balance of your sword.

Being the heaviest part of the koshirae after the saya, you could wind up with a heavier sword than expected if you put a heavy tsuba on a light sword. You'd also bring the balance point closer to the hand.

We use 100g as a measuring stick to judge if a tsuba is heavy or not. If you want a light blade, we recommend a tsuba that weighs 100g or less. If you want a longer, heavier blade, something over 100g would suit it better.

Fuchi Kashira

It's important to choose a design you like if you're going to be using something a long time. However, the size of the fuchi and kashira can affect the thickness of the tsuka.

Check the size of the fuchi kashira when you find a set you like. We recommend men use sets that measure 40mm or larger and women use ones that are 40mm or smaller.

Furthermore, fuchi kashira that are 39mm or smaller look best on narrow blades because the saya is also thinner. On the other hand, blades longer than 2.8.0 (2shaku 8sun) and thick blades will look a little off balance visually if you put a set that's smaller than 41mm on them and in some cases the nakago of the blade won't fit well.

Please keep these factors in mind while choosing your fuchi kashira.

Length of the Tsuka

Tsuka that are 1/3 the length of the saya are the visually ideal balance for koshirae made for Japanese sword appreciation.

However just like the length of the sword, it's important to select a tsuka that suits the user well.

We used our 50 years of experience making iaito for martial artists to create a chart of tsuka lengths that are appropriate for the length of our blades. Please start there when figuring out how long you want your tsuka to be.

This is just a reference, so those with large hands should select a longer tsuka and iaidoka that practice iaido styles that grip the tsukagashira should choose a shorter tsuka.

Tsuka Length Reference Chart

Blade Length (shaku.sun.bu)	Thick Blade (sun.bu)	Thin Blade (sun.bu)	Narrow Blade (sun.bu)
Consult us about shorter blades			
2.2.0	-	7.4	7.5
2.2.5	7.9	7.9	7.5
2.3.0	7.9	7.9	-
2.3.5	8.3	8.3	-
2.4.0	8.3	8.3	-
2.4.5	8.5	8.5	-
2.5.0	8.8	8.5	-
2.5.5	8.8	8.8	-
2.6.0	9.0	-	-

Consult us about longer blades

Menuki

All the menuki in our catalog are appropriate for martial arts use.

Feel free to choose any design you like.

Some menuki are thicker than others, a factor that can affect the overall thickness of the tsuka. Thick menuki are denoted with a mark, so please keep this in mind.

The menuki in our "Large Menuki" section are a good match for long tsuka that exceed 9shaku 5sun in length. It's possible that the tsuka won't fit in your hand properly if they're used on a regular tsuka, so be careful when ordering them.

On the other hand, choosing regular menuki for a very long tsuka will likely give it a reserved, low-key appearance.

We have 3 positions for menuki: standard, reverse, and center.

The majority of our customers choose the standard position, but some iaido styles require different placement.

Menuki Position

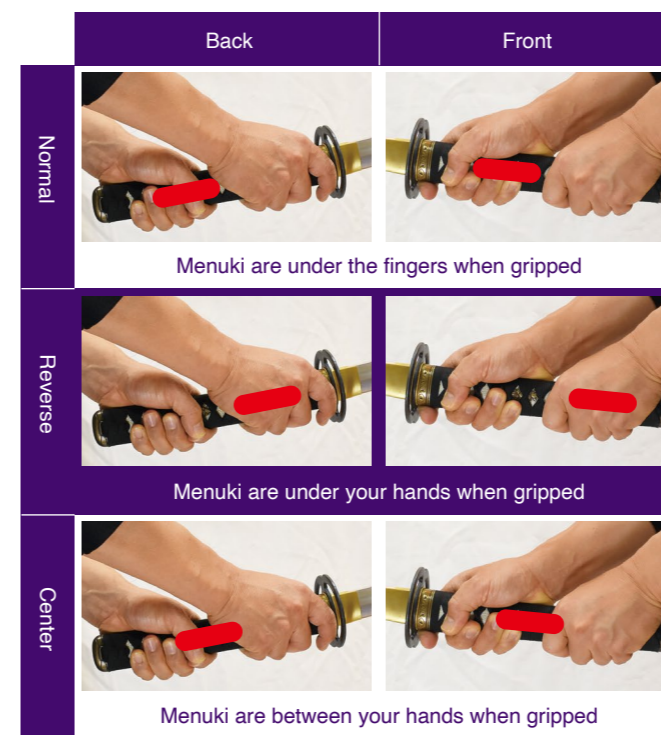

Differences Between Our Iaito Series

	Tsuba	Fuchi Kashira Kojiri					Menuki			Habaki			Bo-Hi	
		Can Choose Design	Can Choose Design	Aged Brass x2	Aged Brass x3	Silver x2	Silver x3	Can Choose Design	Aged Brass	Silver	Brass			Shinken-Hi
											Plain	Yujo/Shonai		
Shoden	¥5,500 (Youth Ed Excl)	No	Standard	—	—	—	¥2,200 (Youth Ed Excl)	Standard	—	Standard	—	—	—	
Chuden	Yes	Yes	Standard	¥16,500	¥11,000	¥30,800	Yes	Standard	¥5,500	Standard	¥11,000	¥22,000	—	
Okuden Nosyusaku	Yes	Yes	¥-3,300	Standard	¥7,700	¥16,500	Yes	Standard	¥5,500	—	Standard	¥11,000	¥6,600	
Okuden Shinkensaku	Yes	Yes	—	—	¥-5,500	Standard	Yes	—	Standard	—	—	Standard	¥6,600	

The Shape of the Tsuka

Using a tsuka that doesn't suit your grip can be a source of discomfort during long practices.

Whether or not a tsuka feels thick or thin varies greatly from person to person. We recommend "egg" shaped tsuka for people with large hands and "flat" shaped tsuka for people with small hands.

Also, some iaido styles require a particular tsuka shape. If you already practice iaido, please consult with your teacher and seniors.

Tsuka Shapes

※Top of the images are the ha side, bottom the mune
 ※The shapes are exaggerated for clarity.

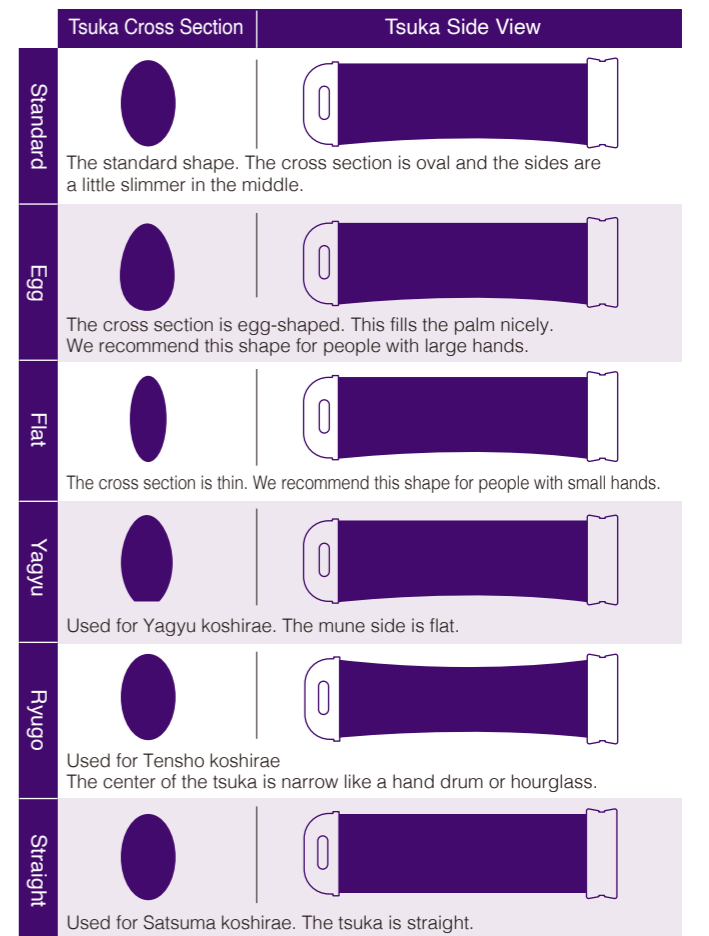

Shinken -Mei-

People have appreciated the elegance, beauty, and strength of Japanese swords for centuries. Each of the gokaden have beauty and strength in their characteristic shape, hamon, and jigane and can be used for iaido or appreciation.

Kanemichi
兼道
Seki, Gifu Prefecture
Studied under his father, Kanetoki, and inherited his grandfather's name
Mino-den Soshu-den

Kanetoki
兼時
Seki, Gifu Prefecture
Studied under his father, Kanemichi, and inherited his grandfather's name
Mino-den Soshu-den

Akamatsutaro Kanemitsu
赤松太郎兼光
Yatsushiro, Kumamoto Prefecture
Studied under his father, Akamatsutaro Kanetsugu. He received the special Kunzan Award at the 2022 & 2023 Gendai Toshokuten.
Akamatsutaro Kanehiro
赤松太郎兼裕
Yatsushiro, Kumamoto Prefecture
Studied under his father, Akamatsutaro Kaneshige. Kanemitsu's uncle.
Akamatsutaro Kaneyuki
赤松太郎兼幸
Yatsushiro, Kumamoto Prefecture
Studied under his father, Akamatsutaro Kanetsugu. The younger brother of Kanemitsu.

Hiromune
弘宗
Seki, Gifu Prefecture
Living national treasure. Studied under both Miyairi Yukihiro and his father, Takaba Makoto.
Mino-den Soshu-den

Fusataro
房太郎
Hashima, Gifu Prefecture
Studied under the 25th generation Fujiwara Kanefusa
Mino-den Soshu-den
Bizen-den

Kanekuni
兼國
Yamagata, Gifu Prefecture
Mukansa (certified 12/2009). Studied under his father, Kanekuni (Ogawa Kunihiko), who was also mukansa.
Soshu-den

Kazuyoshi
和吉
Miyako, Iwate Prefecture
Studied under Miyamoto Tokuharu (Yoshimitsu)
Bizen-den Yamato-den

Shiro Kunitada
四郎國忠
Omuta, Fukuoka Prefecture
Studied under his grandfather, the first generation Shiro Kunimitsu
Soshu-den
Shiro Yasumitsu
四郎安光
Omuta, Fukuoka Prefecture
Studied under his grandfather, the first generation Shiro Kunimitsu
Soshu-den
Shiro Kunimitsu
四郎國光
Omuta, Fukuoka Prefecture
Studied under his grandfather, the first generation Shiro Kunimitsu
Bizen-den

Sadahito
貞人
Mishima, Shizuoka Prefecture
Studied under his father, Sadayoshi, who learned sword smithing from Gassan Sadakatsu
Soshu-den

So Masachika
宗昌親
Fukuoka, Fukuoka Prefecture
Mukansa (certified 2006). Studied under his father, So Tsutomu
Soshu-den Bizen-den

Not only do we here at Nosyudo do our best to understand our customers' requests, the swordsmiths use the best of their abilities to create a shinken to order. We also have a well-stocked selection of shinken in our shop. We can give you a list of shinken we have ready that meets your requirements, or you are welcome to have a blade order made.



Special Terminology
※Mukansa The highest level of master swordsmith. Including living national treasures, there are only about 20 in Japan.
※Gokaden The five schools of sword smithing divided by the region they are from: Yamashiro-den (Kyoto), Yamato-den (Nara), Soshu-den (Kamakura, Kanagawa), Bizen-den (Okayama), and Mino-den (Seki, Gifu).

Shinken Construction Examples

Polish Regular/Appreciation/Tameshigiri Shira-togi
Nugui (kesho-togi) Sashikomi (Non-kesho; brings out natural hamon)

Bo-Hi Carving Kakinagashi/Kakitoshi (ends under habaki) (continues to end of nakago) Marudome/Bo-hi
A normal bo-hi can reduce the weight of the blade by about 100g. We can usually reduce the weight by 30-50g if we alter an existing bo-hi. We can also carve a bo-hi into a polished blade. Important precautions must be taken while carving the bo-hi

Umegane In bo-hi/ji/shinogi/mune
Umegane is the art of covering up flaws in the blade that resulted from the metal folding process. Depending on the location of the flaw, polishing may be necessary.

Shirasaya Regular/Appreciation Hatame • Waterbuffalo Horn Insert • Tsunagi

Maki-e
We can do kamon and other designs

Tsukamaki Regular/Appreciation Hinerimaki • Tsumamimaki • Leather • Shabaramaki
※Samples on P35-36

Same Same attached to tsuka base ※Same color samples on P36
Tanzaku Makisame front Makisame back - the edges meet

Koshirae Regular/Appreciation Tsukamaki Same • Sayamaki Same Inrokizumi
Uchigatana Koshirae Tensho Koshirae • Higo Koshirae • Yagyū Koshirae • Toppei Koshirae
Tanto Koshirae Aikuchi Dashisame Koshirae Tachi Koshirae (tsuka & saya making)
Higo Koshirae Kanshitsu Vermillion Stone • Kusube Leather Tsukamaki
Uchigatana Koshirae Black Shinobue • Black Silk Tsukamaki
Water buffalo horn insert
Wooden Base Samples Tsuka Base Saya Base - Koikuchi Close-up

Seppa Ready Made/Hand Made copper • silver • gold • silver plated • gold plated

Habaki

Copper Yujo	Copper Shonai	Copper Kashu	Silver Kamon	Silver Owari
Silver Yujo	Silver Shonai	Silver Botan Yujo	Ginkise Single Sayagata	Kinkise Sayagata
Kinkise Yujo	Kinkise Shonai	Kinkise Double	Kinkise Double Sayagata	Uegai Kinkise Shitagai Shakudo

Koshirae Examples



Aikuchi Koshirae



Aikuchi Dashisame Koshirae



Kaiken Koshirae - With Kamon



Aikuchi Dashisame Koshirae - Black Same With Kozuka



Tanto Toyokiku Koshirae



Aikuchi Dashisame Toyokiku Koshirae - Gold-Brown Nashiji



Ebi Saya Koshirae

Naginata Koshirae



Yari Koshirae



Tachi Koshirae



Uchigatana Koshirae



Tensho Koshirae



Tensho Koshirae
black leather hinerimaki
black same
water buffalo horn kashira
kakemaki



Tensho Koshirae
green leather hineri maki
red-black same
water buffalo horn kashira
kakemaki



Handachi Koshirae silk steel blue hineri maki - antique same - gold-brown nashiji saya



Uchigatana Koshirae silk antique black - katatsumami maki - sendan kizami black stone saya

Fuchi Kashira Kojiri Samples



All of our metal fuchi, kashira, and kojiri are available in silver and aged brass

SET Daito & washizaki set available
 ◎ Kuwagata Kojiri require an extra ¥5,500 installation fee

Silver / KS-00	Funagata Kojiri	¥13,200	Aged Brass / KY-00			
Fuchi	Large Funagata Kojiri (▲ mark)	¥14,300	Fuchi	¥11,000	Kojiri	¥11,000
Kashira	¥13,200	Kuwagata Kojiri (◎ mark)	¥14,300	Kashira	¥11,000	

<p>SET Rope L 39 S 37.5 (mm) silver KS-1 a. brass KY-1</p>	<p>SET Vines L 41 M 40 S 39 (mm) silver KS-2 a. brass KY-2</p>	<p>Dragon L 41.5 S 39 (mm) silver KS-4 a. brass KY-4</p>	<p>Higo Karakusa 39 (mm) silver KS-5 a. brass KY-5</p>	<p>SET Nami Kusa L 40 S 37.5 (mm) silver KS-7 a. brass KY-7</p>
---	---	--	--	--

<p>Wave 40 (mm) silver KS-8 a. brass KY-8</p>	<p>Bird 40.5 (mm) silver KS-9 a. brass KY-9</p>	<p>Dragonfly 40 (mm) silver KS-11 a. brass KY-11</p>	<p>Higo Stone 40 (mm) silver KS-12 a. brass KY-12</p>	<p>Hiranami Higo L 42.5 S 41 (mm) silver KS-13 a. brass KY-13</p>
---	---	--	---	---

<p>Ajiro 40.5 (mm) silver KS-14 a. brass KY-14</p>	<p>Arrowhead 40 (mm) silver KS-15 a. brass KY-15</p>	<p>Kyo Sukashi 38.5 (mm) silver KS-16 a. brass KY-16</p>	<p>Maple Leaf ◎ 40 (mm) silver KS-17 a. brass KY-17</p>	<p>SET High Wave L 41 M 39 S 36 (mm) silver KS-18 a. brass KY-18</p>
--	--	--	---	---

<p>Sansrit 40 (mm) silver KS-19 a. brass KY-19</p>	<p>Kobusho 40 (mm) ◎ silver KS-20 a. brass KY-20</p>	<p>SET Peony Karakusa L 44 M 42 M 40 S 37 (mm) silver KS-21 a. brass KY-21</p>	<p>Flower Raft 39 (mm) silver KS-22 a. brass KY-22</p>	<p>Higo Musashi ◎ 41 (mm) silver KS-24 a. brass KY-24</p>
--	--	---	--	---

<p>Mino Dragon ◎ L 44 S 41 (mm) silver KS-25 a. brass KY-25</p>	<p>Higo Wave ◎ 40 (mm) silver KS-26 a. brass KY-26</p>	<p>Plum Blossom 38.5 (mm) silver KS-27 a. brass KY-27</p>	<p>Kiku Karakusa L 40 S 39.5 (mm) silver KS-28 a. brass KY-28</p>	<p>Paulownia (Hideyoshi) 38.5 (mm) silver KS-29 a. brass KY-29</p>
---	--	---	---	--

<p>Higo Rivet 40.5 (mm) silver KS-30 a. brass KY-30</p>	<p>Zuiun ◎ 39.5 (mm) silver KS-31 a. brass KY-31</p>	<p>Tensho L 47 L 45 S 40 (mm) silver KS-32 a. brass KY-32</p>	<p>Guribori 40.5 (mm) silver KS-33 a. brass KY-33</p>	<p>Yagyū Kasa L 41 S 39.5 (mm) silver KS-36 a. brass KY-36</p>
---	--	---	---	--

※The fuchi & kashira can affect the shape & thickness of the tsuka. ※If you select fuchi & kashira that are larger than 40.5mm, your tsuka may be wider than the saya.
 ※◎Kuwagata kojiri often have uneven results with regular saya finishes. We recommend Kanshitsu finishes (P39). Includes both registered and unregistered designs.

All fuchi, kashira, and kojiri are available in silver & aged brass



※The fuchi & kashira can affect the shape & thickness of the tsuka. ※If you select fuchi & kashira that are larger than 40.5mm, your tsuka may be wider than the saya.
※©Kuwagata kojiri often have uneven results with regular saya finishes. We recommend Kanshitsu finishes (P39).

SET Daito & washizaki set available

©Kuwagata kojiri require an extra ¥5,500 installation fee

Includes both registered and unregistered designs.

Introduction

Iaito

Special Iaito

Shinken

Koshirae-Iaito • Shinken

Other Equipment

Menuki

All of our menuki are available in silver and aged brass.

Silver/MS-00 ¥8,800
Aged Brass/MY-00..... ¥3,900



Peas silver MS-2 a. brass MY-2	Arrowhead silver MS-6 a. brass MY-6	Dragon Twisted Sword silver MS-7 a. brass MY-7	Triple Paulownia silver MS-9 a. brass MY-9	Sparrow silver MS-10 a. brass MY-10
Bee silver MS-11 a. brass MY-11	Daikoku silver MS-12 a. brass MY-12	Koi silver MS-13 a. brass MY-13	Dokko Sword silver MS-14 a. brass MY-14	Kiku silver MS-16 a. brass MY-16
Kiku & Daffodils silver MS-17 a. brass MY-17	Small Kiku silver MS-18 a. brass MY-18	Holly silver MS-19 a. brass MY-19	Single Kiku silver MS-20 a. brass MY-20	Dragonfly silver MS-22 a. brass MY-22
Phoenix silver MS-23 a. brass MY-23	Kanji Characters silver MS-26 a. brass MY-26	War Fan silver MS-27 a. brass MY-27	Crane silver MS-28 a. brass MY-28	Three Cranes silver MS-29 a. brass MY-29
Sword & Armor silver MS-30 a. brass MY-30	Gourd & Catfish silver MS-31 a. brass MY-31	Autumn Flowers silver MS-37 a. brass MY-37	Plum Blossom silver MS-38 a. brass MY-38	Deer & Maple Leaves silver MS-39 a. brass MY-39
Tiger & Bamboo silver MS-40 a. brass MY-40	Wave & Koi silver MS-41 a. brass MY-41	Pine silver MS-42 a. brass MY-42	White Crane silver MS-43 a. brass MY-43	Old Bones silver MS-44 a. brass MY-44
Boat silver MS-45 a. brass MY-45	Tree & Phoenix silver MS-46 a. brass MY-46	Tiger silver MS-48 a. brass MY-48	Rain Dragon silver MS-49 a. brass MY-49	Catfish silver MS-50 a. brass MY-50
Marishiten silver MS-51 a. brass MY-51	Kirin silver MS-53 a. brass MY-53	Japanese Pepper silver MS-55 a. brass MY-55	Crane in Sunrise silver MS-56 a. brass MY-56	Samurai silver MS-57 a. brass MY-57

Plover silver MS-58 a. brass MY-58	Butterflies silver MS-60 a. brass MY-60	Lion Couple silver MS-61 a. brass MY-61	Botan Kiku silver MS-62 a. brass MY-62	Paulownia & Phoenix silver MS-66 a. brass MY-66
Bamboo silver MS-67 a. brass MY-67	Flower Basket silver MS-68 a. brass MY-68	Old Coins silver MS-70 a. brass MY-70	Kakotsuruhe silver MS-73 a. brass MY-73	Flower Raft silver MS-74 a. brass MY-74
Daffodil silver MS-75 a. brass MY-75	Three Step Pine silver MS-76 a. brass MY-76	Tiger & Cub silver MS-77 a. brass MY-77	Mino Kiku silver MS-78 a. brass MY-78	Bamboo & Sparrow silver MS-79 a. brass MY-79
Crab silver MS-81 a. brass MY-81	Wave & Maple silver MS-83 a. brass MY-83	Katsujin Ken silver MS-84 a. brass MY-84	Camellia silver MS-85 a. brass MY-85	Peony & Lion silver MS-86 a. brass MY-86
Sanscrit silver MS-87 a. brass MY-87	Plum Branch silver MS-88 a. brass MY-88	Mukade silver MS-90 a. brass MY-90	Squirrel & Grapes silver MS-92 a. brass MY-92	Crescent Moon silver MS-93 a. brass MY-93
Falcon & Pine silver MS-94 a. brass MY-94	Aizen Myo-o silver MS-97 a. brass MY-97	Twisted Mino Dragon silver MS-98 a. brass MY-98	Fudo Myo-o silver MS-99 a. brass MY-99	Bishamonten silver MS-100 a. brass MY-100
Rabbit silver MS-101 a. brass MY-101	River Crab silver MS-102 a. brass MY-102	Peony silver MS-104 a. brass MY-104	Kyo Phoenix silver MY-105 a. brass MY-105	Old Bones (Large) silver MS-106 a. brass MY-106
Three Monkeys silver MS-108 a. brass MY-108	Sparrow in Bamboo silver MS-109 a. brass MY-109	Watanabe Tsuba silver MS-110 a. brass MY-110	Cloud Dragon silver MS-111 a. brass MY-111	Maple Leaves silver MS-112 a. brass MY-112
Bamboo & Tiger silver MS-113 a. brass MY-113	Kasen Sword Bean silver MS-116 a. brass MY-116	Aun Lion silver MS-117 a. brass MY-117	Dancing Tigers silver MS-118 a. brass MY-118	See P.41 for large menuki.

Introduction

Iaito

Special Iaito

Shinken

Koshirae-Iaito・Shinken

Other Equipment

Tsuba

Please let us know if you'd like to use an antique tsuba or provide your own when you place your order.



Iron (No plating) ¥16,500 Aged silver plating ¥23,100 (iron base price + ¥6,600) Aged brass plating ¥23,100 (iron base price + ¥6,600)

● Suitable for swords 2.4.5 & longer ● Suitable for swords 2.3.0 & shorter ✦ Silver tsuba available SET Daito & washizaki set available

Iron Example



Aged Silver Example

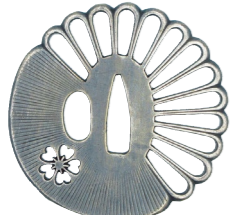

Aged Brass Example



All our plating options are rust resistant. *Not rust-proof.



T-7 Maple ● ✦
75g
70.5×68.5×5.0(mm)



T-8 Scaled Dragon
110g
73.5×70.0×4.9(mm)



T-9 Cloud Dragon ✦
95g
73.5×68.5×4.3(mm)



T-10 Square Plum ●
100g
69.0×67.5×5.6(mm)
▲ No Restock



SET
T-11 Ginkgo S ●
L 85g 78.5×75.0×5.1(mm)
S 65g 72.0×69.0×5.0(mm)



T-13 Sakura & Horse ●
135g
80.5×75.0×3.6(mm)



T-14 Fan
120g
77.0×76.5×3.9(mm)
▲ No Restock



T-15 Bamboo & Tiger ✦
110g
78.0×75.0×2.6(mm)



T-16 Wave & Koi ✦
120g
76.5×69.0×3.7(mm)



T-17 Harness & Baton ✦
110g
74.0×70.0×3.9(mm)



T-19 Bird ●
125g
80.5×75.0×3.3(mm)



T-20 Gourd ✦
90g
76.0×74.5×3.5(mm)
▲ No Restock



T-21 Dragon Fly
130g
76.5×69.5×5.3(mm)



T-24 Wicker ●
90g
73×66.5×3.2(mm)
▲ No Restock



T-25 Arrowhead ✦
105g
75.0×70.0×3.3(mm)



T-27 Bamboo Leaves
90g
79.0×75.0×4.7(mm)



SET
T-28 Wave & Plover L S ●
L 125g 75.5×70.5×4.1(mm)
S 75g 65.0×58.0×3.7(mm)



T-172 Ono Daimoku
125g
74.5×78.5×4.5(mm)



T-30 Cormorant & Basket ✦
75g
74.5×72.5×4.2(mm)



SET
T-31 Kinai L S ● ✦
L 85g 77.0×75.0×3.4(mm)
S 60g 67.5×65.0×3.7(mm)
▲ No Restock



T-32 Cloud ●
60g
73.0×72.5×2.9(mm)
▲ No Restock



T-34 Catfish ✦
95g
73.0×71.5×4.2(mm)

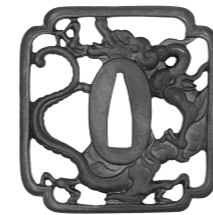

T-35 Square Dragon L S ●
L 115g 74.0×71.0×5.5(mm)
S 95g 71.5×69.0×5.0(mm)



T-36 Yagyu ✦
90g
73.0×73.0×4.3(mm)



T-37 Small Plum ● ✦
80g
68.0×64.5×5.3(mm)



T-39 Kiku Karakusa L S ●
L 115g 82.5×78.0×2.8(mm)
S 110g 78.5×74.0×2.8(mm)



T-41 Sukashi Dragon ✦
100g
77.0×73.5×4.0(mm)

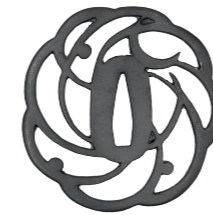

T-44 Mikazuki Musashi L S ●
L 90g 81.0×79.0×4.4(mm)
S 65g 76.5×75.0×3.5(mm)



T-173 Masayoshi Kiku
150g
81.5×75.5×4.0(mm)



T-46 Sanscrit
100g
75.5×70.5×3.6(mm)

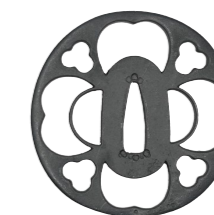

T-47 Kanayama ● ✦
75g
72.5×71.5×4.8(mm)

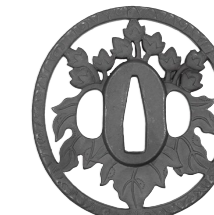

T-49 Paulownia (Hideyoshi) ✦
95g
75.0×71.5×4.9(mm)



T-51 Flower Raft ●
85g
71.0×67.0×4.3(mm)



T-58 Kyo Kiku Sukashi ✦
80g
79.5×79.0×4.0(mm)



T-60 Hijikata
135g
76.5×69.5×4.6(mm)



T-61 Yagyu Kasa ✦
110g
78.0×71.0×2.8(mm)

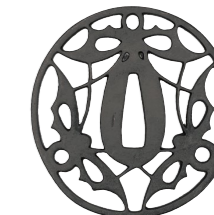

T-63 Butterfly Sukashi ● ✦
70g
77.0×74.0×4.0(mm)



T-65 Sakura Kiku Sukashi ✦
95g
71.5×71.5×4.0(mm)



T-66 Kinai Dragon ✦
90g
76.0×76.5×4.0(mm)



T-76 Guribori Sukashi ●
105g
79.5×79.5×4.7(mm)



T-78 Owari ●
80g
81.5×80.5×4.2(mm)



T-79 Deer & Maple ●
105g
78.0×73.0×4.4(mm)



T-80 Choshu Dragon ●
130g
82.0×81.0×4.9(mm)



T-82 Yagyu Kasa in Bamboo ●
90g
75.0×71.0×4.5(mm)

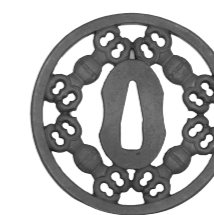

T-84 Dokko Sword ●
80g
72.0×72.5×4.0(mm)



T-90 Old Coins (Nobunaga)
100g
76.0×76.5×3.2(mm)
▲ No Restock

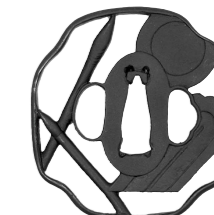

T-91 Brush
75g
70.5×67.5×4.6(mm)
▲ No Restock



T-93 Lion ● ✦
125g
78.0×72.0×3.5(mm)

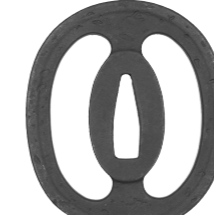

T-95 Miyamoto Musashi ✦
85g
77.5×67.5×4.6(mm)

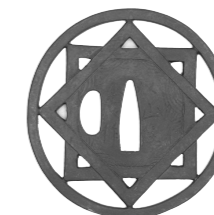

T-96 Rankanzu ✦
85g
77.0×75.0×3.5(mm)



T-97 Echizen Dragon ●
110g
79.0×78.0×4.5(mm)



T-98 Torii & Man ●
90g
70.0×67.0×3.9(mm)

Introduction

Iaito

Special Iaito

Shinken

Koshirae-Iaito • Shinken

Other Equipment



T-99 Katsujin Ken
130g
77.0x70.5x4.2(mm)

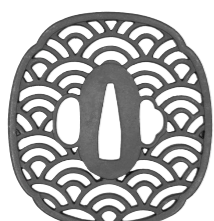

T-101 Seigaiha
90g
77.0x73.0x4.1(mm)



T-102 Choshu Cloud Dragon
90g
76.5x74.0x3.4(mm)



T-103 Proportional Pine
95g
77.5x77.5x4.1(mm)

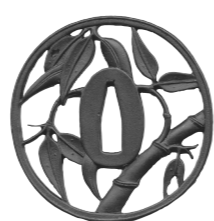

T-105 Bamboo
90g
77.5x76.0x4.7(mm)



T-137 Ai (Kanetsugu)
105g
75.5x71.5x3.9(mm)



T-138 Crab
90g
77.0x74.0x3.7(mm)



T-139 Longevity Higo Tiger
95g
76.0x73.0x3.8(mm)



T-140 Phoenix
L 120g 78.5x75.0x4.5(mm)
S 105g 77.0x73.0x4.0(mm)



T-142 Kiku Flowers
L 100g 80.0x80.0x4.5(mm)
S 90g 77.5x77.0x4.2(mm)



T-106 Praying Mantis
115g
76.0x70.5x3.4(mm)

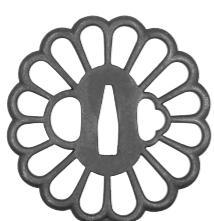

T-107 Tadatoki Kiku
85g
78.0x77.5x4.8(mm)



T-108 Munenori Warriors
95g
74.5x70.0x4.1(mm)



T-109 Spiderweb
105g
76.0x73.5x3.1(mm)



T-110 Carp in Wave Sukashi
95g
77.5x77.0x4.3(mm)

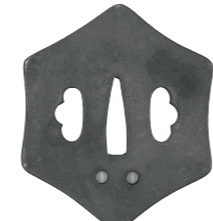

T-144 Hanjiro
L 155g 83.0x70.5x5.6(mm)
S 140g 78.5x67.0x5.6(mm)



T-145 Mokko Sayagata
155g
81.0x75.0x5.0(mm)



T-146 Rabbit
65g
74.0x72.0x3.3(mm)

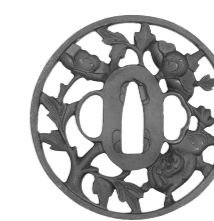

T-147 Chinese Lions & Peony
95g
79.0x79.0x4.4(mm)



T-148 Peony Blossoms
85g
80.0x75.0x4.0(mm)



T-111 Satsuma Tiger
140g
81.0x76.0x3.7(mm)



T-112 Butterflies
125g
82.5x74.5x3.3(mm)



T-113 Rain Dragon
110g
73.5x70.5x4.9(mm)



T-114 Daikoku
105g
78.0x69.0x4.5(mm)



T-116 Victory Dragonfly
105g
80.5x74.5x2.7(mm)



T-153 Watanabe Kiku
105g
74.0x71.0x4.8(mm)



T-154 Old Bones
150g
80.5x75.0x4.1(mm)



T-155 Mt Horai
115g
76.0x72.5x4.0(mm)



T-156 Hirato Kunishige Dragon
110g
73.0x68.5x4.3(mm)



T-158 Broad Wave
105g
77.5x76.5x4.0(mm)



T-118 Awa
105g
76.5x69.0x4.1(mm)



T-119 Bamboo & Tiger Sukashi
90g
76.0x73.0x4.0(mm)



T-120 Chinese Lion
85g
77.0x72.5x3.1(mm)

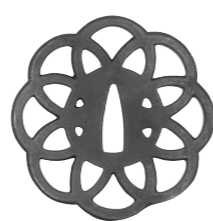

T-121 Nine Rings
105g
82.0x81.0x4.3(mm)



T-122 Masachika Plum
95g
77.5x77.0x4.2(mm)



T-159 Umetada Kiku
100g
82.0x74.0x2.8(mm)



T-160 Mito Dragon
120g
80.0x75.5x4.1(mm)

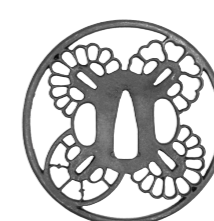

T-161 Sukashi Tsuba
85g
80.5x80.0x4.6(mm)



T-162 Seiho Pine
120g
73.0x70.0x5.0(mm)



T-163 Satsuma Maple
125g
77.0x72.0x5.0(mm)



T-124 Dancing Dragonflies
110g
77.5x72.5x4.1(mm)



T-126 Plovers at Sunrise
140g
78.5x76.0x4.0(mm)



T-127 Old Coins
135g
76.0x76.5x3.8(mm)



T-128 Egret
135g
78.5x78.5x3.6(mm)



T-129 Sansui Masatoyo
110g
75.0x71.5x2.7(mm)



T-164 Bamboo & Crab
145g
82.0x77.0x3.3(mm)



T-165 Dewy Bamboo
80g
78.5x78.5x4.2(mm)



T-166 Kasen Butterfly Sukashi
85g
74.0x74.0x4.9(mm)

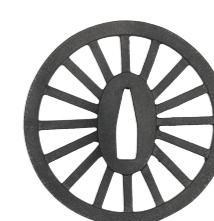

T-167 Sekiwa Sukashi
85g
79.0x79.0x4.3(mm)



T-168 Great Sakura & Maple
L 125g 75.0x70.0x4.5(mm)
S 110g 72.0x67.0x4.5(mm)



T-130 Vines (For Tachi)
115g
78.0x71.0x3.4(mm)

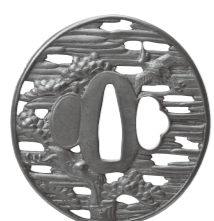

T-132 Pine & Crane
100g
75.0x71.5x4.4(mm)



T-133 Plum & Uguisu
115g
83.0x78.5x3.4(mm)



T-135 Peony
130g
77.0x76.5x4.3(mm)



T-136 Falcon in Pine
125g
75.5x70.0x4.3(mm)

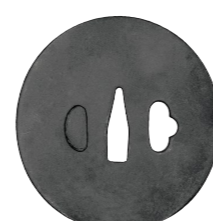

T-169 Kenjo
115g
79.0x75.0x3.6(mm)



T-171 Ume Tree Mokko
140g
84.5x81.0x4.6(mm)

Aged Silver Example **Aged Brass Example**

		Iron (No plating) ¥16,500
		Aged silver plating ¥23,100 (iron base price + ¥6,600)
		Aged brass plating ¥23,100 (iron base price + ¥6,600)

All our plating options are rust resistant.
 ※ Not rust-proof.
 ※ Plating may take 1-1.5 months in some cases.

● Suitable for swords 2.4.5 & longer ✦ Silver tsuba available
 ● Suitable for swords 2.3.0 & shorter SET Daito & washizaki set available

Tsukamaki

Iaido calls for a sturdy tsukamaki. Please tell us your desired menuki position and how long, thick, and what shape tsuka you'd like when you order.



TT-01 Katatemaki +¥5,500



TT-02 Hiramaki



TT-03 Hinerimaki Standard ※We use this by default if no other tsukamaki is specified



TT-05 Karauchi Katatemaki -Shinken Only-



TT-06 Gangimaki



TT-08 Katatsumamimaki

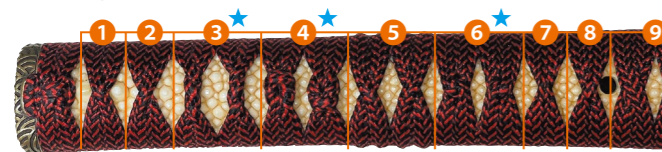

- 1 Moro Tsumamimaki
- 2 Kata Tsumamimaki
- 3 Nejirimaki
- 4 Musubidama
- 5 Shinomaki
- 6 Karamemaki
- 7 Moro Hinerimaki
- 8 Kata Hinerimaki
- 9 Hiramaki

★..... Added in one spot flair on swords made for appreciation.

Tsukaito Colors

Cotton -TM-



TM-02 Brown ※Shown with black same



TM-01 Black



TM-03 Steel Blue



TM-04 Azuki



TM-05 Uguisu



TM-06 Purple



TM-07 Golden Brown

Silk -TS-



TS-01 Black



TS-02 Antique Black



TS-03 Azuki



TS-04 Light Brown



TS-05 Steel Blue



TS-06 Anique Steel



TS-07 Light Steel Blue



TS-08 Uguisu



TS-09 Navy Blue



TS-10 Green



TS-11 Purple



TS-012 Golden Brown



TS-13 White



TS-14 Dark Green



TS-15 Rouge ※Shown with black same



TS-16 Brown

Cow Leather -TC-

※The front side is shiny and smooth. ※The back has a matte, downy texture.



TC-01F Black (Front)



TC-01B Black (Back)



TC-04B Green (Back)

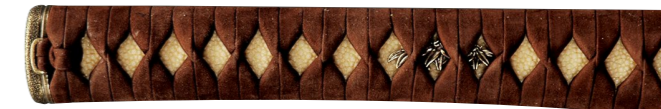

TC-03B Dark Brown (Back)

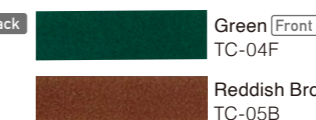
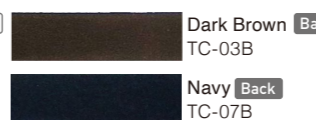
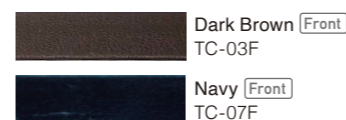

Pig Leather -TP-

※The back has a matte, downy texture.

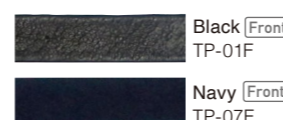

Deer Leather -TB-

※Shinken only ※Front side only ※Kusube -TB-09F- is also available.



Same Color

※See P24 for same attachment styles



White



Antique +¥2,200



Black +¥2,200



Red-Black +¥5,500

※ Please understand that leather is a naturally-derived material and thus may have unique marks.

Saya Finishes

Base Prices **A** No additional **B** ¥6,600 **C** ¥16,500 **D** ¥22,000 **E** ¥24,200 **G** ¥33,000 **H** ¥35,200
 For saya bases provided by customers **A** ¥16,500 **B** ¥17,600 **C** ¥19,800 **D** ¥22,000 **E** ¥24,200 **G** ¥33,000 **H** ¥35,200

A Standard



SY-01 Black Gloss SY-02 Black Stone

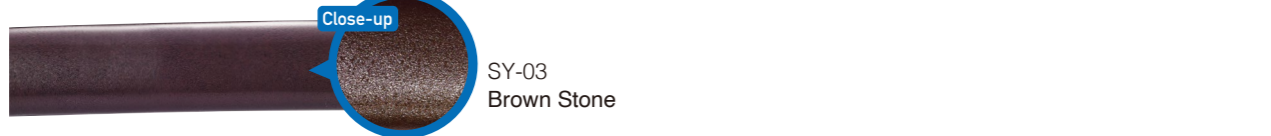

SY-03 Brown Stone

B



SY-05 Brown Stone Gloss SY-44 Wine Gloss



SY-45 Dark Rouge Gloss SY-56 Vermillion Gloss



SY-54 Wine Stone SY-93 Dark Rouge Stone

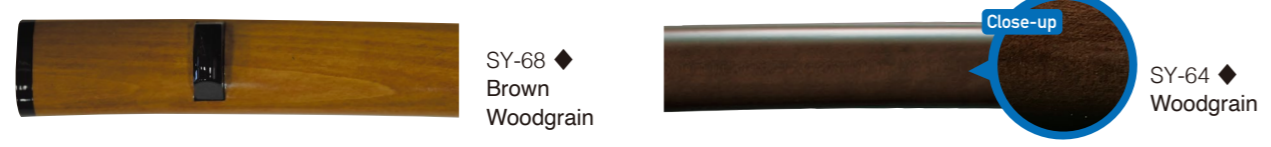

SY-68 ◆ Brown Woodgrain SY-64 ◆ Woodgrain



SY-70 ◆ Black Kakishibu SY-69 ◆ Black Woodgrain

C



SY-42 Navy Gloss SY-86 Purple Gloss

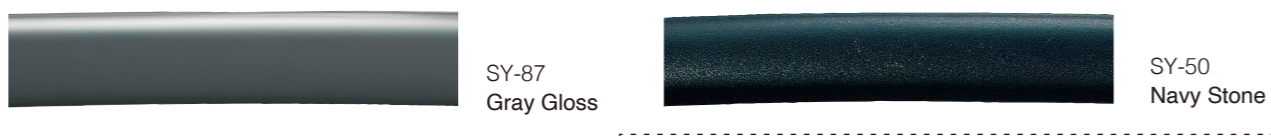

SY-87 Gray Gloss SY-50 Navy Stone



SY-90 Gray Stone SY-40 ¥22,000 Gold-Brown Nashiji

D

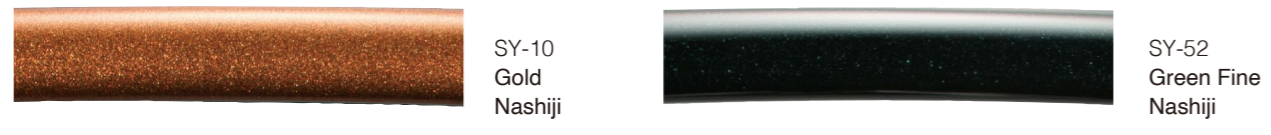

SY-10 Gold Nashiji SY-52 Green Fine Nashiji



SY-53 Green Nashiji SY-83 Red Nashiji

D E

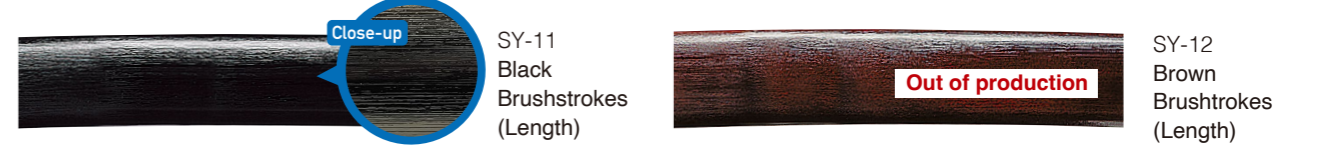

SY-11 Black Brushstrokes (Length) SY-12 Brown Brushstrokes (Length) **Out of production**

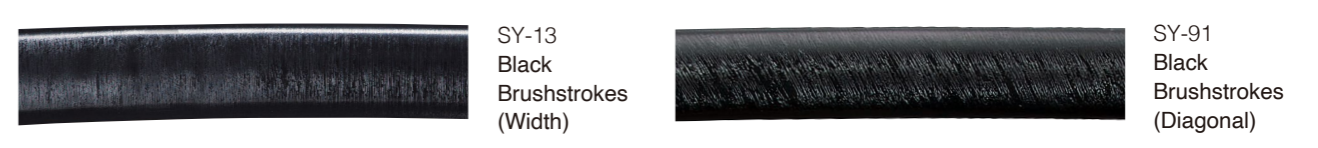

SY-13 Black Brushstrokes (Width) SY-91 Black Brushstrokes (Diagonal)



SY-101 Dark Brown Brushstrokes (Length) SY-102 Dark Brown Brushstrokes (Width)



SY-15 Black Tataki SY-17 Brown Tataki



SY-71 Navy Tataki SY-72 Dark Rouge Tataki



SY-73 Green Tataki SY-18 Urumi/Brown Gloss



SY-74 Navy Hirumaki SY-75 Vermillion Hirumaki



SY-76 Isokusa SY-62 Kin Mushikui

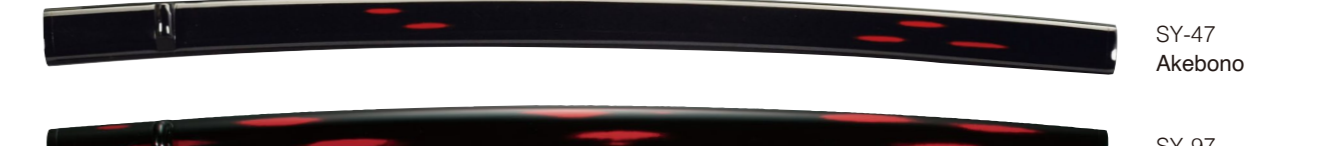

SY-47 Akebono



SY-97 Akebono (Extra)



SY-49 Negoro



SY-88 Silver Akebono

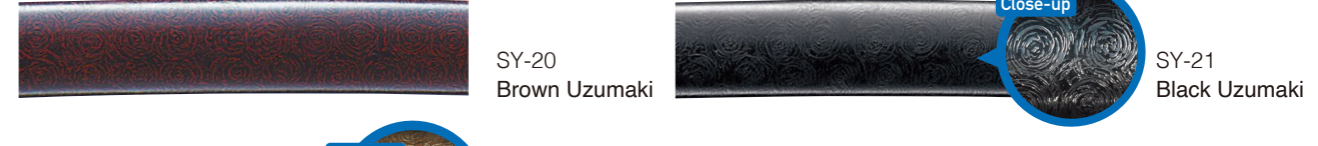

SY-89 Gray Kasuri SY-21 Black Uzumaki

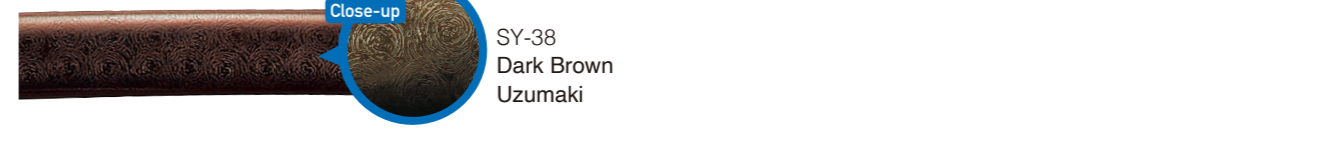

SY-20 Brown Uzumaki SY-38 Dark Brown Uzumaki

※ Because finishes marked with ◆ show the wood grain of the saya, we cannot attach kuwagata kojiri or change the position of the kurigata on iaito.
 ※ Additional fees may be applied when metal fittings are added to saya (EX: funagata kojiri is +¥2,200~)
 ※ When a saya is provided to be repainted, additional fees and a limitation to finish options may be applied depending on its condition.

※ Colors in this catalog may differ from the actual colors ※ Other options available

Kanshitsu Stone A finish that involves applying layers of dried urushi laquer, giving this stone/ishime finish its unique, high quality feel.

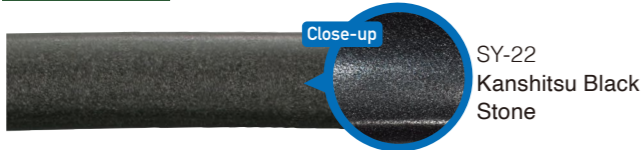

SY-22
Kanshitsu Black Stone

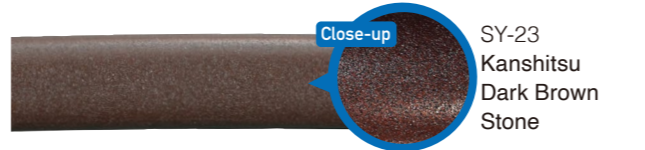

SY-23
Kanshitsu Dark Brown Stone



SY-36
Kanshitsu Red-Brown Stone



SY-37
Kanshitsu Vermillion Stone



SY-65
Kanshitsu Green Stone

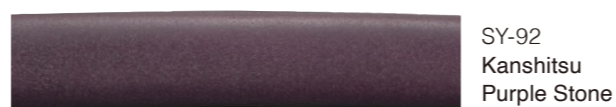

SY-92
Kanshitsu Purple Stone



SY-94
Kanshitsu Gray Stone

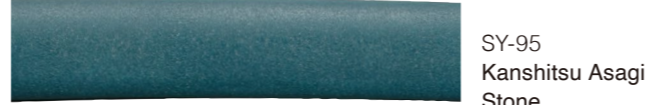

SY-95
Kanshitsu Asagi Stone



SY-24
Brown Tsuishu



SY-25
Green Tsuishu



SY-66
Blue Tsuishu

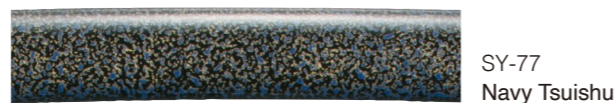

SY-77
Navy Tsuishu



SY-78
Vermillion Tsuishu



SY-59
Brown Tsuishu Shinobue



SY-26
Blac Shinobue



SY-80
Navy Shinobue



SY-81
Vermillion Shinobue



SY-28
Black Aogai



SY-29
Tsunobue Aogai

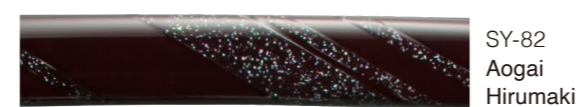

SY-82
Aogai Hirimaki

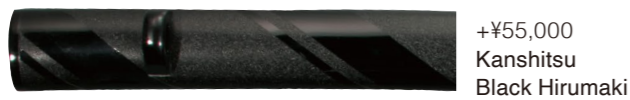

+¥55,000
Kanshitsu Black Hirimaki



+¥58,300~
Sendan Kizami Black Gloss



+¥8,800
Partial Fujimaki Black Gloss



+¥52,800~
Inro Kizami Black Gloss



SY-46 +¥16,500
Partial Same Wrap (Straight) Smooth Same with Black Gloss



SY-48 +¥19,800
Partial Same Wrap (Diagonal) Smooth Same with Brown Stone

Other Fittings • Materials

Metal Tachi Fittings

※ Brass base metal

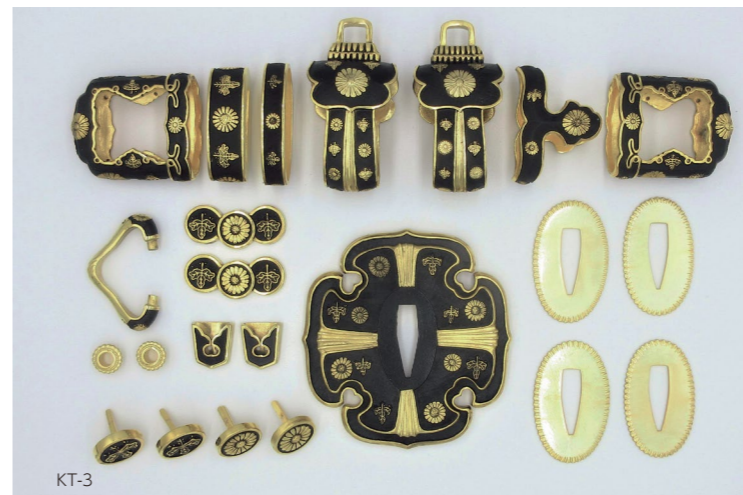

Metal Tachi Fittings KT-3 Kiku+Paulownia ※ "Black & Gold" pictured above
Antique Gold ¥223,900 Aged Silver ¥223,900
Black & Gold ¥346,000



Metal Tachi Fittings KT-1 Karakusa ※ "Aged Silver" pictured above
Aged Silver ¥194,700 Aged Brass ¥194,700
Gold plate ¥282,700



Metal Tachi Fittings KT-2 Stone Finish
※ "Antique Gold" pictured above
Aged Silver ¥194,700 Aged Brass ¥194,700
Gold plate ¥282,700



Metal Tachi Fittings KT-4 Maru ni Ken Katabami
※ "Aged Silver" pictured above
Aged Silver ¥286,600 Aged Brass ¥286,600
Black & Gold ¥468,100



Metal Tachi Fittings KT-5 Kawari Efudachi
※ "Aged Brass" pictured above
Aged Silver ¥316,800 Aged Brass ¥316,800
Gold plate ¥452,100

Metal Tanto Fittings



Metal Tanto Fittings KE-12 Wave & Plover for Maezashi
Aged Silver ¥116,600
Aged Brass ¥116,600
Gold plate ¥168,300



Metal Tanto Fittings KE-13 Ebi Saya Koshirae
Aged Silver ¥143,000 Aged Brass ¥143,000
Gold plate ¥202,400



Metal Tachi Fittings KT-6 Metal Efudachi Fittings
Aged Silver ¥243,700 Aged Brass ¥243,700
Gold plate ¥352,600



KA-1 Shitodome Cover



KA-1



KA-1

Metal Fittings for Tanto - Aikuchi

KA-1 Toyo Kiku
Built-in Shitodome Aged Silver ¥77,000
Aged Brass ¥66,000
Shitodome Cover Aged Silver ¥85,800
Aged Brass ¥73,700

Metal Fitting Sets

※ "Silver" pictured below

Hiranami Higo

Fuchi•Kashira•Kojiri silver KS-13 a. brass KY-13
Koikuchi KE-72 Kurigata KE-82



Higo Wave

Fuchi•Kashira•Kojiri silver KS-26 a. brass KY-26
Koikuchi KE-73 Kurigata KE-83



Wave & Plover

silver KS-124 a. brass KY-124



Stone Fuchi•Kashira•Kojiri silver KS-42 a. brass KY-42
Koikuchi KE-71 Kurigata KE-81



Musashi silver KS-46 a. brass KY-46



Awa Fuchi•Kashira•Kojiri silver KS-102 a. brass KY-102
Koikuchi KE-76 Kurigata KE-84



Ayanami silver KS-116 a. brass KY-116

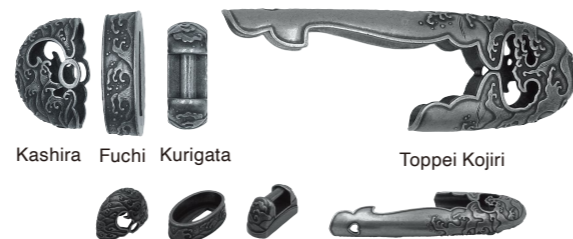

Large Menuki

Silver(MS) ¥11,000
Aged Brass(MY) ¥5,500



Large Twisted Dragon
silver MS-15 a. brass MY-15



Large Tiger
silver MS-95 a. brass MY-95



Sword Bean
silver MS-96 a. brass MY-96



Rain Dragon L
silver MS-103 a. brass MY-103

Toppei Kojiri

KE-61 Silver XL ¥22,000
L ¥11,000
Aged Brass XL ¥17,600
L ¥8,800



Metal Ebizaya Koshirae Kojiri
KE-14
Aged Silver ¥16,500
Aged Brass ¥16,500



Metal Kurigata

Silver ¥13,200
Aged Brass .. ¥11,000



Metal Koikuchi

Whether or not we can use these on your saya depends on the size of your saya.
Silver ... ¥7,700 Brass ... ¥6,600 ※ "Silver" pictured below



Metal Yari Fittings

Aged Silver ... ¥55,000 Aged Brass ... ¥55,000
※ "Aged Brass" pictured below



Kogai

Iroage ¥7,700

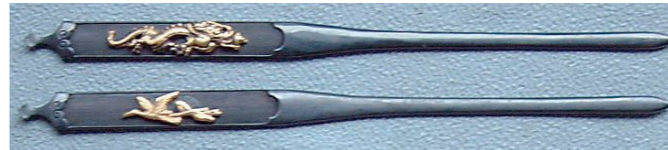

Kozuka

Iroage ¥7,700



Shitodome

Silver Plated ¥1,100 Silver ¥4,400
Gold Plated ¥1,100



Metal Naginata Fittings

Aged Silver ... ¥55,000 Aged Brass ... ¥55,000 ※ "Aged Silver" pictured below



Warikogai

Silver ¥22,000



Seppa

Silver Plated ... ¥3,300 Brass ... ¥1,320
Gold Plated ... ¥3,300

※ Available in 1mm, 1.2mm, 1.5mm thick sets



Tsukaito per 1m

Cotton	¥450
Silk	¥1,200
Pig Leather F B	¥1,600
Cow Leather F B	¥1,600

※ We don't sell deer leather
※ Katana need about 4m for one tsuka

Cardboard Box for Katana Per box

Standard Inner Box/1 Sword -up to 100cm-	¥350
Standard Outer Box/1 Sword	¥400
Long Inner Box/1 Sword -up to 110cm-	¥400
Long Outer Box/1 Sword	¥450
Extra Long Inner Box/1 Sword -up to 120cm-	¥420
Tanto Inner Box -up to 45cm-	¥250

※ These are the same boxes we use to ship our company's swords
※ Outer boxes are just big enough for the inner boxes to fit.
We recommend using them together for sturdier packaging
※ Inner box inner dimensions: 9cmx7cm (WxH)

Tanto Tsuba



KE-91 For Tanto
40.8x25.5x5.5(mm)
Silver 35g ¥13,200
Brass 30g ¥11,000

Other Equipment



■ Tosensui
(L) Spray ¥1,100
(R) Refill ¥1,600



■ Uchiko ¥990



■ Katana Oil
15cc ¥500
30cc ¥700
100cc ¥1,600



■ Fujishiro Katana Oil ¥2,200



■ Maintenance Kit in Paper Box
Contents: Katana Oil/Uchiko
Nugui/Oil Cloth Case ¥1,800



■ Maintenance Kit in Wood Box
Contents: Katana Oil/Uchiko
Nugui/Oil Cloth Case ¥2,900



■ Travel Maintenance Kit ¥5,500
▲ Back when closed
Contents:
• Pleather case
• Katana Oil
• Uchiko
• Mekugi-nuki
• Oil Cloth
• Nugui

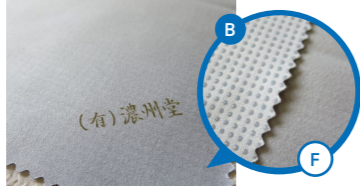

■ Microfiber Cloth ¥880
Features a non-slip finish on one side. One side has a super soft microfiber cloth to wipe your blade with. The safe, non-slip finish on the other side is for your hand.



■ Oil Cloth ¥120



■ Oil Cloth Refill ¥660



■ Nugui ¥300



■ Mekugi Nuki ¥1,500



■ Katana Makura ¥1,600



■ Kizuchi ¥4,400



■ Paulownia Boxes
For Tsuba ¥2,200 (w/o cushion)
For Menuki ¥2,200 (w/o cushion)
For Fuchi & Kashira ¥2,200 (w/o cushion)



■ Paulownia Boxes
For 1 Tachi ¥38,500 For 1 Wakizashi ¥33,000 For 1 Tanto ¥28,500
For 2 Tachi ¥44,000 For 2 Wakizashi ¥38,500 For 2 Tanto ¥33,000



■ Wagara Sword Bag ¥2,900



■ Wagara Drawstring Bag ¥2,900



■ Embroidered Bag For Tachi ¥5,500
For Wakizashi ¥5,000
For Tanto ¥4,500
※ Available w/ fabric tie or with Fusa



■ Fusa (Left) L / (Right) S ¥800



■ Taki Model Sword Case ¥22,000
L 121cm M 108cm S 102cm
Fits 2 iaito, 2 kaezaya, maintenance kit, & other small items.



■ Pleather Sword Case
For 2 Up to 116cm/2.5.0 ¥12,000 M Up to 110cm/2.4.5 ¥4,900
XL Up to 118cm/2.7.0 ¥4,900 S Up to 106cm/2.3.5 ¥4,900
L Up to 114cm/2.6.0 ¥4,900 XL Up to 100cm/2.2.0 ¥4,900
■ High-End Sword Case Black·Navy·D. Brown ¥22,000 each
■ Leather Sword Case Black·Navy·D. Brown ¥40,000 each



■ Tameshigiri Stand ¥28,600



▲ Pictured with mat
■ Makiwara ¥670



Cardboard Iaido Practice Stand

- Made from sturdy and light cardboard.
- Height is adjustable.
- Can be cut with an iaito.
- Clean and easy tameshigiri prep.
- You can easily try out tameshigiri.
- Check if your nukitsuke & kiritsuke are correct.
- Check your distance.
- Can practice tameshigiri with shinken or iaito

● Use a weight to stabilize the stand when in use.

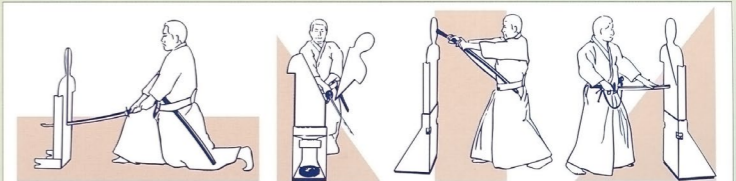

■ Cardboard Iaido Cutting Stand Stand & Torso (x10) Set ¥9,900 Torso Refill (x10) ¥4,950



■ Adjustable Acrylic Katana Stand ¥8,800



■ Katana Stand -Flat Pack- ¥6,600



■ Quality Katana Stand ASK



■ Quality Katana Stand -With Drawer- ¥27,500 Limited



■ Tachi Stand ¥9,900



[Weaves]



- Silk Sageo ¥5,500 each
- Handwoven Silk Sageo ¥22,000 each
- Handwoven Silk Tanto Sageo ¥19,800 each



■ Cotton Sageo ¥1,100 each



For protecting your koikuchi
■ Koikuchikun ¥700



■ Zekken ¥3,400



■ Knee Pads (M/L) ¥3,000 ※Black only



■ White Tabi ¥2,750~



■ Martial Arts Tabi ¥5,000~



■ Setta ¥2,800~



■ Referee Flags Red & White Set ¥1,200



■ Martial Arts Hanger ¥2,200

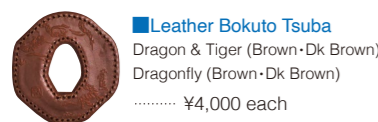

■ Leather Bokuto Tsuba
Dragon & Tiger (Brown·Dk Brown)
Dragonfly (Brown·Dk Brown)
..... ¥4,000 each



■ Leather Bokuto Tsuba (High Quality)
..... ¥4,000



■ Bokuto & Plastic Saya Set ¥8,530

■ Plastic Saya ¥3,800



■ Bokuto & Wooden Saya ¥22,000



■ White Oak Jo ¥5,500

Books·DVD

※Japanese version only



Introduction to Japanese Swords through Pictures ¥1,650



Introduction to Japanese Swords through Pictures II ¥1,650



Handbook of the Japanese Sword ¥1,800

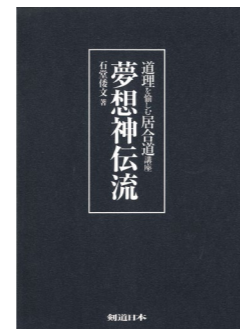

Muso Shinden Ryu Course
Book 1 Shoden Omori Ryu
Book 2 Chuden Hasegawa Eishin Ryu
Book 3 Okuden Okuiai
..... Three Volume Set with Cover ¥6,600



Iaido From the Referee's Eyes ¥2,200

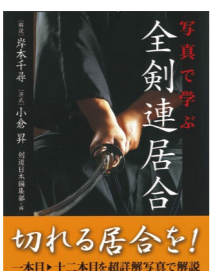

Introduction to All Japan Kendo Iaido through Pictures ¥1,980



Advanced Iaido Course ¥2,750



DVD Practice Iaido ~Inner Secrets~
Koryu Muso Shinden Ryu
Koryu Muso Shinden Jushin Ryu
Koryu Muso Jikiden Eishin Ryu
Koryu Shinkage Ryu
Koryu Hoki Ryu
Koryu Mugai Ryu
Koryu Tamiya Shinken Ryu
..... ¥10,000 each

Iaigi

Prices vary by size.



■ Kimono Sleeves

- Polyester (B W) ¥22,000~
- Summer Polyester w/out Juban (B W) ¥25,000~
- Faux Tsumugi (B W) ¥27,000~
- Polyester Koshoku Habutae (B) ¥66,000~



■ Tube Sleeve

- Polyester (B W) ¥18,700~
- Summer Polyester (B W) ¥21,000~
- Faux Tsumugi "Akebono" (B W) ¥23,000~
- Faux Tsumugi "Akatsuki" Summer (B W) ¥21,000~
- Children's Tetron Select (B W) ¥7,200~
- Taka Shirushi Tetron (B W) Made To Order ¥22,000~

Size Charts

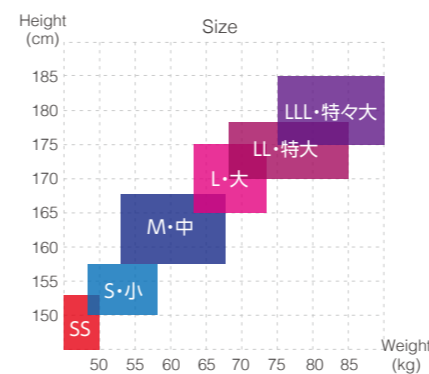
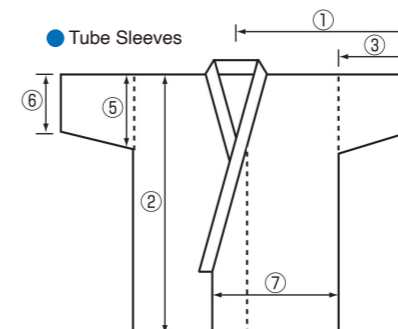
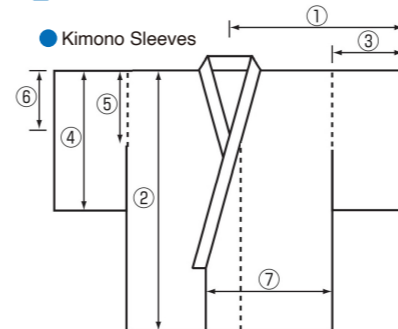

Kamon Application (5)

■ Stenciled ¥16,500~

■ Stick-on ¥8,800~

※Fabric kamon stickers can be attached to black kimono
※An additional ¥3,300 may be required for kamon not in our catalog.



■ Iaigi Set - Navy

- Bushu Ikkyoku Jojiju "Kachiki" ¥22,000~
- Bushu Silk Touch Hakama "Banri" ¥29,000~



■ Juban

- Tube Sleeves ¥4,400~
- Kimono Sleeves ¥7,000~
- Daruma (Tube Sleeves) ¥6,600~
- Summer Tube Sleeves ¥8,800~



■ Faux Tsumugi Obi (B W) ¥5,500 each



■ Stretch Obi (B W) ¥5,500 each



■ Polyester Obi (B W) ¥4,800 each



■ Cotton Kaku Obi (B W N) ¥5,500 each



■ Cotton Obi (B) ¥4,400



■ Tetron Hakama ■ Wool Hakama

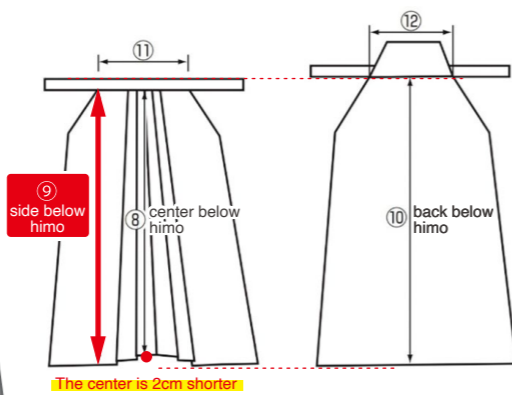

※We also do name embroidery (¥150 per character)
 ※Hakama size and shape varies by maker. If you'd like to consult us before buying, please send us the measurements ⑧ - ⑩ and your waist and hip measurements.

Size	⑨ side below himo(cm)	Approx. Height	
		Men	Women
22.5	85	154	146
23.0	87	158	150
23.5	89	162	154
24.0	91	166	158
24.5	93	170	162
25.0	95	174	166
25.5	97	178	170
26.0	99	182	174
26.5	101	186	178



■ Polyester Hakama
 There are tabs on the front and back to keep your hakama from sagging
 1 Hakama tab ¥200

- Hakama
- Polyester (IH770) ¥18,700~
 - Polyester Summer Ver. **(B)(W)** ¥21,000~
 - Faux Tsumugi "Akebono" **(B)(W)** ¥25,000~
 - Faux Tsumugi "Akatsuki" For Summer **(B)(W)** ¥25,000~
 - Children's Tetron Select ¥7,700~
 - Taka Shirushi Tetron ¥25,000~
 - Striped Wool Hakama ¥38,000~

■ Striped Wool Hakama Samples

● Wool 25% • Tetron 75%

◆ Wool 40% • Tetron 60%

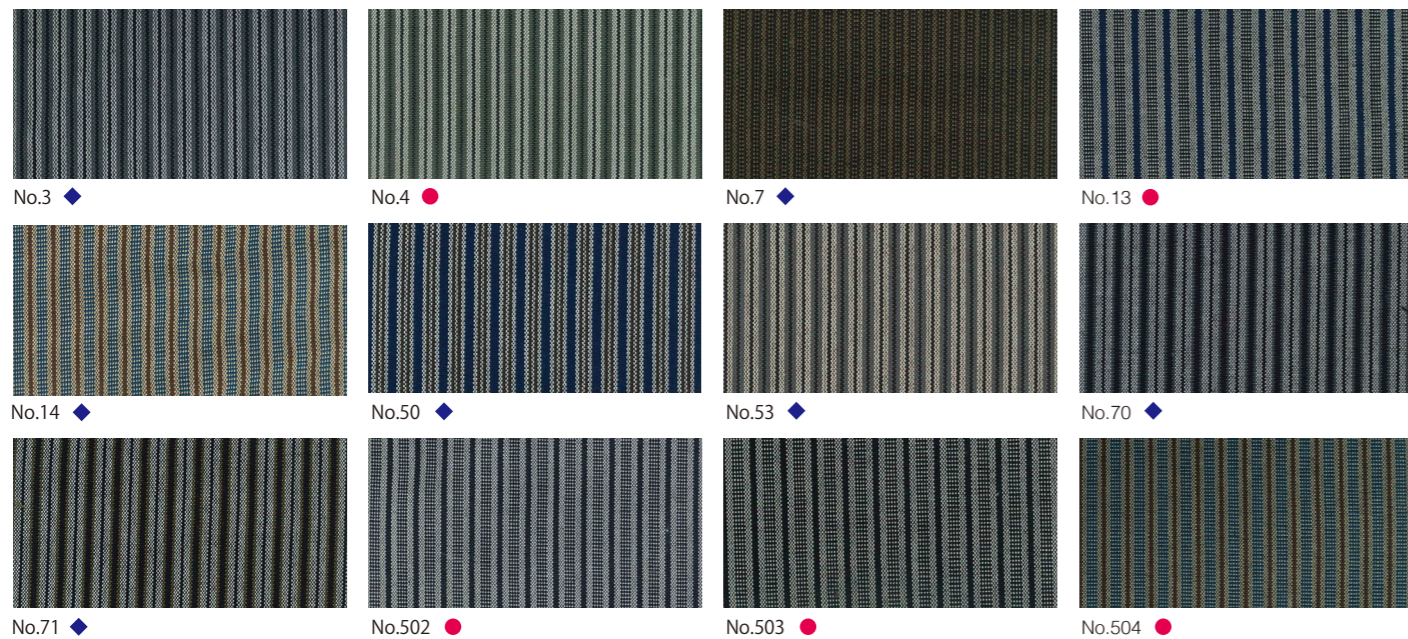

NEW ■ Striped Wool Hakama Samples

● Wool 30% • Tetron 60%

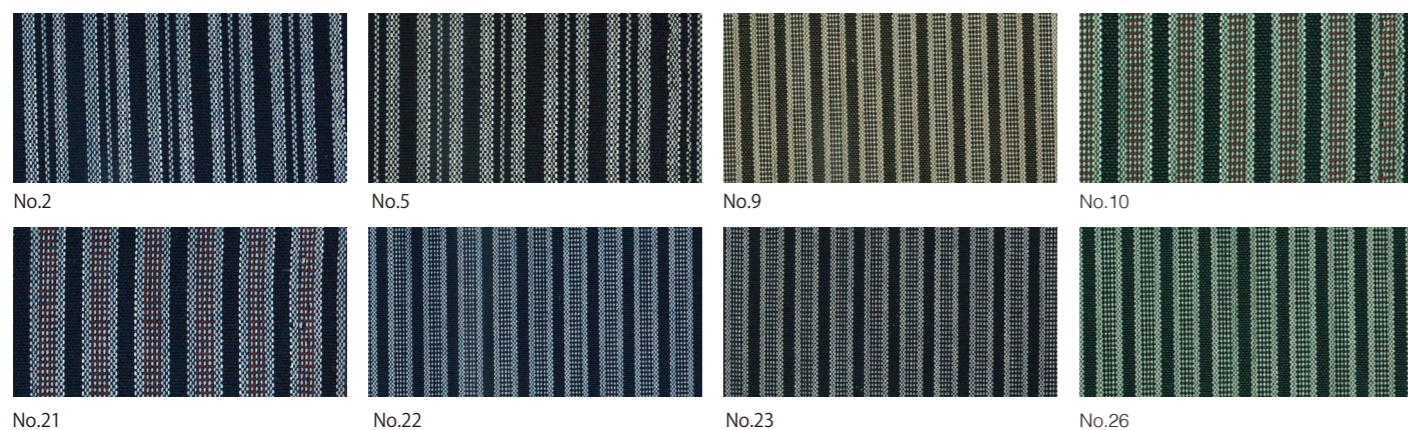

How to Order

We accept orders by phone, fax, post, internet, and e-mail. We primarily take overseas orders by e-mail.

◆ Ordering Iaito ◆

We start preparing orders upon receipt of your order form. Please contact us about our English order form. We will begin making your Iaito once we confirm the payment is complete.

◆ Repairs ◆

Please fill out and send the "Iaito Repair Request Form" on P51 with your Iaito. If you need a shinken repaired, please send both a completed copy of the "Shinken Work Request Form" and either the original or a copy of the sword registration card with your sword. Please make sure to note the desired repairs or construction on the form or in a letter. If you know the name of the staff member helping you, please also write their name. If sent domestically, please use "Yu-pack" at the post office. If sending a sword from overseas, be sure to send it via post office and not an independent delivery company. Please contact us before mailing a shinken for repairs. Various fees and paperwork are required to import and export shinken. It takes about three months to import a shinken into Japan and about a month to export one. Please only use the national post office, not a private shipping company, so send your shinken to Japan.

◆ Shipping ◆

The customer is responsible for shipping expenses in all cases, including repeated attempts.

◆ Cancellations ◆

We charge a 30% cancellation fee on orders cancelled after production has begun. The payment will be reimbursed minus the 30% fee. We expect the customer to pay for any fees related to the reimbursement. We do not accept cancellations on repairs. Be sure to confirm any details with us and carefully check the estimate sheet before payment. The contents of the estimate will take priority over verbal or written information.

Payment

Please mark your desired payment method on your order form.

◆ Bank Transfer ◆

We accept bank transfers through the bank and through Wise. Any fees incurred are to be covered by the customer. You can see our Wise transfer information below

BENEFICIARY'S BANK NAME: THE OGAKI KYORITSU BANK, LTD. (0152)
 BRANCH NAME: SEKI BRANCH (011) BENEFICIARY'S BANK
 SWIFT CODE: OGAKJPJT (ABA(Fedwire code)AND IBAN are not required for Japan)
 BENEFICIARY'S A/C TYPE: FUTSU (普通) BENEFICIARY'S A/C NO.: 587663

◆ PayPal ◆

We accept payments via PayPal. Any fees incurred are to be covered by the customer.

◆ Convenience Store Payment ◆ (Domestic Only)

We'll provide you with an estimate form and if your ordering from Japan, a payment form. This form of payment can be used in all participating convenience stores within Japan. This option is only available in Japan.

◆ Credit Card ◆

We accept credit card payment by Mastercard and VISA in store and online. We require your email or LINE contact information for online payment. In the case of international orders, we will send a credit card payment link.

Shipment Time

All of our completion times are estimates. Actual completion time can vary greatly depending on the contents of your order and the number of orders we are handling. Please let us know if you require the sword by a certain date. We also have ready-made options available in our shop.

◆ Estimated Time to Complete ◆

- Shoden Iaito: 1.5 months+ • IaiGi•Hakama: 1.5 months+
- Chuden Iaito: 1.5 months+ • Repairs depend on the condition of the sword and the requested services.
- Okuden Nosyusaku•Shinkensaku: 3.5 months+

Shipping Fees

Actual shipping costs depend on the size of package sent
 The delivery company and date/time cannot be selected if more than 3 swords are shipped (applies to domestic shipments)

◆ Shipping (Up to 3 swords) ◆

- Kyushu•Shikoku•Aomori•Iwate•Akita ¥2,100
- Hokkaido ¥3,300
- Okinawa ¥4,500
- Outlying Islands ¥4,000~
- Honshu ¥2,000
- International ¥5,000+

◆ COD Fees ◆ (Domestic Only)

- Total less than ¥10,000 ¥330
 - Total less than ¥30,000 ¥440
 - Total less than ¥100,000 ¥880
 - Total up to ¥300,000 ¥1,300
- ※We cannot offer COD on orders ¥300,000+

Nosyudo Price List

Catalog

※Prices include tax

Iaito

Shoden

※Shoden product numbers vary by tsuba and tsukaito options

Thick Blade Cotton Tsukamaki

Higo	/No.10-M	¥49,500
Musashi	/No.11-M	¥49,500
Shiho Sukashi/No.15-M		¥49,500
Yatumokko	/No.17-M	¥49,500
Mokko	/No.18-M	¥49,500

Thick Blade Real Same Silk Tsukamaki

Higo	/No.10-S	¥58,850
Musashi	/No.11-S	¥58,850
Shiho Sukashi/No.15-S		¥58,850
Yatumokko	/No.17-S	¥58,850
Mokko	/No.18-S	¥58,850

Thin Blade Cotton Tsukamaki

Higo	/No.20-M	¥46,200
Musashi	/No.21-M	¥46,200
Shiho Sukashi/No.25-M		¥46,200
Yatumokko	/No.27-M	¥46,200
Mokko	/No.28-M	¥46,200

Thin Blade Real Same Silk Tsukamaki

Higo	/No.20-S	¥55,550
Musashi	/No.21-S	¥55,550
Shiho Sukashi	/No.25-S	¥55,550
Yatumokko	/No.27-S	¥55,550
Mokko	/No.28-S	¥55,550

Youth Edition

Efugo Sukashi	/No.30-M	¥39,600
Shihomokko	/No.31-M	¥39,600
Nanakoji	/No.32-M	¥39,600
Tsurumaru	/No.33-M	¥39,600

Chuden

Igarashi-to (Real Same Cotton Tsukamaki)	¥61,600
Igarashi-to-S (Real Same Silk Tsukamaki)	¥64,900
Igarashi-to-H (Real Same Leather Tsukamaki)	¥77,000

Okuden

Nosyusaku	¥97,900
Nosyusaku with Leather Tsukamaki	¥110,000
Shinkensaku	¥130,900
Shinkensaku with Leather Tsukamaki	¥143,000
Koshirae DX	Additional ¥55,000

For Kendo Kata

Kendo Kata (Daito)	¥49,500
Kendo Kata (Shoto)	¥44,500

Additional fees for long swords

Contact us for details

2shaku 5sun~	¥4,400
2shaku 6sun~	¥7,700
2shaku 6sun 5bu~	¥11,000
2shaku 7sun~	¥22,000 (w/o bo-hi)

Possible blade length depends on the type of blade selected.

※There are various conditions and limitations for blades 2shaku 7sun and longer. Please contact us concerning long blades.

Tsuba

Shoden Tsuba - Iron	¥11,000
Other Tsuba - Iron	¥16,500
Silver	¥48,600~

※Prices for silver tsuba vary depending on the amount of and the current value of silver.

Fuchi Kashira Kojiri

Kashira (Silver)	¥13,200
Fuchi (Silver)	¥13,200
Funagata Kojiri (Silver)	¥13,200
Kuwagata Kojiri (Silver)	¥14,300
Kashira (Aged Brass)	¥11,000
Fuchi (Aged Brass)	¥11,000
Kojiri (Aged Brass)	¥11,000

※Additional cost for o-kojiri (large kojiri).

Menuki

Silver (MS)	¥8,800
Aged Brass (MY)	¥3,900

Metal Koikuchi Fitting

Silver	¥7,700
Aged Brass	¥6,600

Metal Kurigata Fitting

Silver	¥13,200
Aged Brass	¥11,000

Other Metal Fittings

Kozuka Iroage	¥7,700
Kogai Iroage	¥7,700
Warikogai	¥22,000
KE-91 Tsuba for Tanto	¥11,000~
KE-51 Metal Naginata Fittings (4 Piece Set)	
Aged Silver•Aged Brass	¥55,000
KE-52 Metal Yari Fittings (4 Piece Set)	
Aged Silver•Aged Brass	¥55,000
KE-61 Toppei Kojiri	
Aged Brass	8,800円
Silver	11,000円

Iaito Repairs

If your iaito is from another maker, please consult them first.
We can repair iaito from other makers to the best of our ability if necessary.

Iaito Repair Base Costs

Nosyudo **¥2,200**
Other Brands **¥3,300**

This fee covers removing the tsuka, blade, etc and putting everything back together. Repairs that don't require the tsuka to be removed cost ¥1,100. This fee does not include the cost of work or materials needed to repair any problems with the item.

Be sure to check for any looseness in your mekugi peg, tsuba, tsuka, koiguchi, etc before every practice. Removing the tsuka applies stress to the sword. We do not recommend removing the tsuka without reason. Please cease use of your iaito if you feel anything is loose or notice any other problems. We recommend having your sword repaired.

Tsuka Related Repair Fees

Repair loosness/rattling	¥550~
Mekugi change	¥110
Rewrap tsuka (Cotton)	¥12,100~
Rewrap tsuka (Silk)	¥15,400~
Rewrap tsuka (cow/pig leather)	¥27,500~
Tsuka grip adjustment	¥2,200~
Tsuka fitting	¥2,200

Tsuba Related Repair Fees

Repair loosness/rattling	¥550~
Semegane (1 place)	¥2,750
Tsuba change fee (separate cost for new tsuba)	¥1,100

Blade Related Repair Fees

Fixing bent blade	¥550~
Shortening blade (Suriage)	¥2,750~
Fit adjustment for nakago, saya for new blade	¥2,200~

※Please contact us concerning repairs not listed.

※Depending on the condition of the item, there may be some repairs we cannot do or situations where it may be cheaper to have a part remade.

※Current prices may differ from those listed above.

Saya Related Repair Fees

Awase saya (includes koikuchi adjustment)	¥13,200~
Koikuchi	¥2,200~
Koikuchi shimming (fixes loose koikuchi)	¥550~
Repair rattling	¥550~

Cost For Necessary Repair Materials

Same (w/o oya)	¥3,300
Iaito blade (thick)	¥18,700~
Iaito blade (thin•narrow)	¥15,400~
Brass habaki (plain)	¥3,300
Brass habaki (yujo•shonai)	¥14,300
Silver habaki (yujo•shonai)	¥22,000
Seppa (brass) 1 piece	¥660
Seppa (silver plated/gold plated) 1 piece	¥1,650

Iaito Repair Request Form

Store Home Taikai

Name _____ TKC # _____

Address 〒 _____

Phone · FAX _____ Cell _____ PC e-mail _____

※Payment Method: Bank Transfer · Convenience Store Transfer · Credit Card · COD · Paypal · Other :

※Please refrain from sending items such as sword cases that don't need repairs

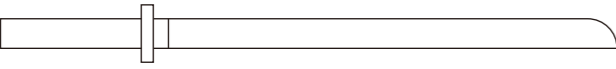
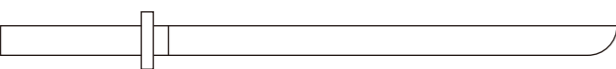
① Iaito Type (Shoden No.10 · No.20 · No.30 · Chuden · Nosyusaku · Shinkensaku · Other Maker) <small>Please circle the kind of iaito you need repaired</small>		Date Received and/or Number
Length (shaku sun bu) Tsuba () Hamon () Tsukamaki material and color () Saya Finish () Other Items With Sword sword case cloth sword bag sageo koikuchikun		
② Base Fee ¥2,200~ Covers removal of fittings from blade to fix rattling, etc. (※ mark indicates fees for various repairs) The fees listed below are not included in the base fee. The cost of repair and related materials are separate.		Amount
③ Please circle the desired repairs.		
Tsuka	Rewrap※ (silk ¥15,400~/cotton ¥12,100~/cow leather·pig leather back·front ¥27,500~) color () Tsukamaki style (hinerimaki · other) menuki placement (standard · center · reverse · other)	
	Adjust thickness ※¥2,200~ thicker/thinner (details:) Note: Rewrapping is also necessary.	
	Rattle repair ※¥550~	
	Mekugi peg replacement ¥110~	
Tsuba	Rattle repair ※¥550~ Mekugi peg replacement ¥110~	
	Semegane※ (1 place ¥2,750·top+bottom ¥5,500) Change (Cost of tsuba not included) ※¥1,100~ Tsuba (T- :) / Provided () Note: Whether or not we can attach the requested tsuba depends on factors such as its thickness, seppadai, etc.	
Seppa	Change※ (1 piece brass ¥660/silver plated ¥1,650/other)	
Habaki	Change※ (plain brass ¥3,300/brass yujo ¥14,300/silver shonai ¥22,000/other) Note: Whether or not we can change the tsuba depends on the blade	
	Rattle/looseness repair ¥550~	
Blade	Straighten bend ¥550~	
	Shorten (suriage) ※¥2,200~ (up to 1sun) Note: The minimum we can shorten the sword is 5bu. Blade change※ (thick ¥18,700~/thin·narrow ¥15,400~) length (shaku sun bu) Hamon () Revival Series Hamon ¥2,200 Weight w/out saya (light · standard · heavy) Note: Whether or not we can change the blade depends on the condition of the koshirae. Also, the habaki may also need to be replaced.	
Saya	Koikuchi shim (fixes loose koikuchi) ¥550~	
	Rattle repair ¥550~ Awase saya (including koikuchi adjustment) ¥13,200~ (black stone./brown stone./black gloss/other)	
Other		
		

〈Note〉 Actual cost of repair and time needed depends on the condition, length, etc of the sword.

Shipping & Handling

Total

Internal use/payment complete · bank transfer form provided

Date Submitted _____

Nosyudo
FAX (0575) 22-2383

Desired Completion Date _____

Dojo/School Name _____

Phone · FAX _____ Cell _____ PC e-mail _____

※Payment Method: Bank Transfer · Convenience Store Transfer · Credit Card · COD · Paypal · Other :

※Let us know if you only need an estimate for reference

Iaito Order Form

Name _____ TKC # _____

Address 〒 _____

Phone · FAX _____ Cell _____ PC e-mail _____

※Payment Method: Bank Transfer · Convenience Store Transfer · Credit Card · COD · Paypal · Other :

※Let us know if you only need an estimate for reference

Iaito ※Please included a scan or photo of your hand for Chuden & Okuden orders.

Series	Name
Shoden Chuden Okuden	

●Required Information (Depending on the series of the iaito, some options may not be available.)
Please see the information pages for each series.

·Blade length [shaku sun bu]

·Weight w/out saya [thick blade · thin blade · narrow blade]
※P21 for reference light · standard · heavy

·Hamon [No preference · HM- single · double]

·Tsukaito Material [cotton · silk · cow leather · pig leather (F·B)]

·Tsukaito Color [black · azuki · steel blue · ()]

·Same Color [white · black · antique · red-black]

·Habaki [plain brass yujo · shonai]
Shoden & Chuden Shinkensaku: silver Nosyusaku: brass

·Tsuba [T- :] ·Tsuba plating [aged brass · aged silver · none]
※rust resistant

·Fuchi & Kashira [K - : (S · M · L) (KY: aged brass · KS: silver)]

·Menuki [M - : (MY: aged brass · MS: silver)]

·Saya Finish [black stone · brown stone · black gloss · other]
+¥1,100 for Youth Edition

·Kurigata Shitodome [none · gold plate. · silver plate.]
+¥1,100

About the user

·Sex [M · F]

·Age []

·Height [cm]

·Reach [cm]

·Ryuha [Ryu]

·[For]

●Optional. Please fill out what you'd like to specify

●Hand copy [provided · none]

Tsuka Length [standard · custom sun bu (cm)]

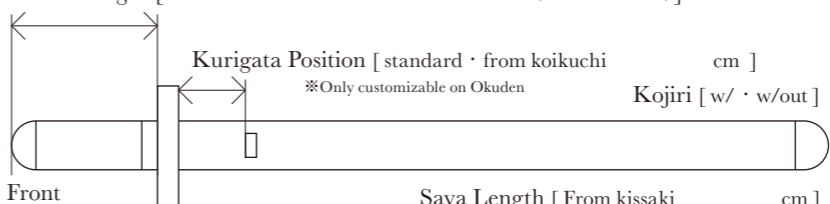

Kurigata Position [standard · from koikuchi cm]
※Only customizable on Okuden

Kojiri [w/ · w/out]

Saya Length [From kissaki cm]
※1sun (~3cm) from kissaki is standard

Menuki Position [standard · center · reverse · custom (please provide chart)]

Tsukamaki Style [hinerimaki · other]

Tsuka Thickness [thin · slightly thin · standard · slightly thick · thick]

Back Tsuka Shape [standard · egg · flat · other]

〈Note〉 The koikuchi of the saya naturally becomes loose with use, so we usually make it tight (1-1.5mm of the habaki is visible). Please let us know if you want a looser koikuchi when you order. The customer is responsible for shipping expenses in all cases, including repeated attempts.

Date Submitted _____

Nosyudo
FAX (0575) 22-2383

Desired Completion Date _____

Dojo/School Name _____

Phone · FAX _____ Cell _____ PC e-mail _____

※Payment Method: Bank Transfer · Convenience Store Transfer · Credit Card · COD · Paypal · Other :

※Let us know if you only need an estimate for reference

◆For Internal Use◆	
Base	
DX Koshirae (Saya · Tsuka)	
Blade Length	
Bo-hi (Shinken Hi · No Bo-hi)	
Select Blade (Yes · No)	
Hamon (Revival Series · Double)	
Tsuka Length	
Tsukamaki (Upgrade)	
Same Color (Black · Antique · Red-Black)	
Habaki (Design · Silver)	
Tsuba (Upgrade · Plating)	
Fuchi & Kashira (Silver)	
Kojiri (Silver)	
Kojiri Attachment (Funagata · Kuwagata)	
Menuki (Silver · Large)	
Saya Finish	
Shitodome (Gold · Silver)	
Silk Sageo (Y · N)	
Sword Case (Y · N)	
Koikuchikun (Y · N)	
Discount for provided parts (Y · N)	
Subtotal	
Shipping & Handling	
Total	

Iaigi・Hakama Order Form

FAX
(0575)22-2383

Customer Contact Info

◎Desired Completion Date

Name: _____ TKC: _____ Dojo: _____

Address _____ Phone・Fax: _____

Cell: _____

PC e-mail _____

Payment Method: Bank Transfer・Convenience Store Transfer・Credit Card・COD・Paypal・Other:

Item Type	Fabric (Circle desired items)	Size	Price
Kimono Sleeves	Polyester Regular : IG-770-K	B・W	¥22,000~
•Size ()	Polyester Summer : Primeflex	B・W	¥25,000~
Kamon Design ()	Polyester Summer : Faux Tsumugi (Akatsuki)	B・W	¥27,000~
(w/circle・w/o circle)	Polyester : Faux Wave Tsumugi (Akebono)	Black	¥29,000~
Size (Standard (~3cm)・Small (~2cm))	Taka Shirushi Polyester Koshoku Habutae : Hand-Sewn Polyester	Black	¥66,000~
•Stick-on ¥8,800 •Print ¥11,000	Like-Silk Montsuki : Stretch Polyester	Black	¥77,000~
•Stencilled ¥16,500	Iai Haori : Polyester	Black	¥26,000~
Tube Sleeves	Polyester Regular : IG-770	B・W	¥18,700~
•Size ()	Polyester Summer : Primeflex	B・W	¥21,000~
Gender (M・F)	Polyester Summer : Faux Tsumugi (Akatsuki)	B・W	¥21,000~
Height (cm)	Polyester : Faux Wave Tsumugi (Akebono)	B・W	¥23,000~
Zekken (Y・N) ※¥2,400	Tetron Regular : Select (for Youth)	B・W	¥7,200~
•Embroidery	Taka Shirushi Tetron : Tailored	Black	¥22,000~
Region ()	Bushu Ikkyokujo Niji : Cotton Kachiki Budogi Cotton	Navy	¥22,000~
Name ()	Sarashi Ikken : Cotton Kendogi・Jodogi	White	¥5,500~
Hakama	Polyester Regular : IH-770	B・W	¥18,700~
•Size ()	Polyester Summer : Primeflex	B・W	¥21,000~
Gender (M・F)	Polyester Summer : Faux Tsumugi (Akatsuki)	B・W	¥25,000~
Height (cm)	Polyester : Faux Wave Tsumugi (Akebono)	B・W	¥25,000~
Embroidery (Y・N)	Tetron Regular : Select (For Youth)	B・W	¥7,700~
•Thread (White・Black・Orange)	Taka Shirushi Tetron : Tailored	Black	¥25,000~
•Name ()	Bushu Ikkyoku Silk Touch : Banri Cotton Kendogi	Navy	¥29,000~
※¥150 per letter	Sarashi Heavy Cotton Hakama (79A) : Cotton Kendo Hakama	White	¥12,000~
	Striped Hakama (Wool-Tetron Blend) : Taka Shirushi 「No.」	Each	¥38,000~
	Striped Hakama (Polyester) : Muso「No.」	Each	¥88,000~
Juban	Tube Sleeve Regular: Marushin Cotton No-Tie	White	¥4,400~
•Size ()	Kimono Sleeve Regular : Marushin Cotton No-Tie	White	¥7,000~
Gender (M・F)	Tube Sleeve Daruma Shirushi Cotton	White	¥6,600~
Height (cm)	Kimono Sleeve Taka Shirushi Cotton with Polyester sleeves	White	¥8,800~
	Tube Sleeve Daruma Shirushi Polyester (Moisture Wicking)	White	¥8,800~
	Kimono Sleeve Daruma Shirushi Polyester (Moisture Wicking)	White	¥9,900~

Size			
Ready Made			
Size Info			
Sizes vary by maker			
• S S (1号・小)			
• S (2号・小)			
• M (3号・中)			
• L (4号・大)			
• L L (5号・特大)			
• 3L (6号・特特大)			
Custom Sizes			
Fill out the measurements for ①-⑫ on the chart below. We will provide a separate estimate.			
[Reference] Estimated Hakama Size			
The length of your hakama will vary depending on the position, width, tying method of the obi, as well as depending on your build			
Size	⑨Side Below Himo Length (cm)	Approx. Height (cm)	
		Men	Women
22	83	150	142
22.5	85	154	146
23	87	158	150
23.5	89	162	154
24	91	166	158
24.5	93	170	162
25	95	174	166
25.5	97	178	170
26	99	182	174
26.5	101	186	178
27	103	190	182

~ Cut Here ~

~ Cut Here ~

- Please check the measurements on the right before asking us about sizes
- ★ Required Information
- Measurements ① - ⑫ are shown on the charts.

Customer Information		Current Iaigi Top		Current Hakama	
★ Height	cm	★ ①Yuki	cm	★ ⑧Front Below Himo	cm
Weight	kg	②Length	cm	★ ⑨Side Below Himo	cm
★ Gender	M・F	★ ③Sleeve Length	cm	★ ⑩Back Below Board	cm
★ Waist	cm	④Sleeve Height	cm	⑪Front Width	cm
★ Hip	cm	⑤Arm hole length	cm	⑫Board Width	cm
Obi Width	cm	⑥Cuff length	cm		
(Usually 8cm)		⑦Okumi	cm		
				★ Required Information	

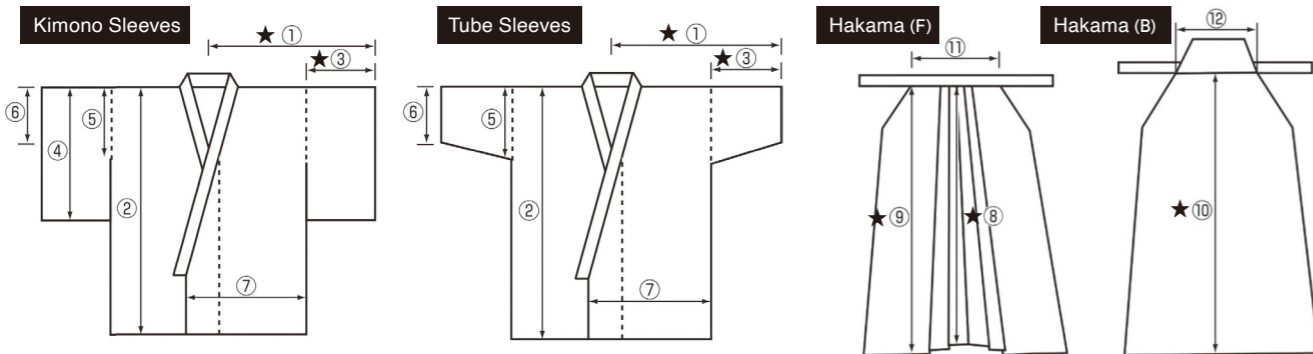

Shinken Restoration

FAX
(0575)22-2383

Customer Contact Info

◎Desired Completion Date

Name: _____ TKC: _____ Dojo: _____

Address _____ Phone・Fax: _____

Cell: _____

PC e-mail _____

Payment Method: Bank Transfer・Convenience Store Transfer・Credit Card
COD・Paypal・Other:

Please note it somewhere on this page if you'd only like an estimate.

Registration Number	Item Name	Amount	Unit Price	Amount
	Repair・Base Cost			
Length	Sori		# of Mekugi-Ana	
Mei (Omote/Ura)				
Date Issued				
Registration (w/・w/o・copy)				
[Items Shipped With Sword] <input type="checkbox"/> None				
<input type="checkbox"/> Synthetic Leather Sword Case	<input type="checkbox"/> Leather Sword Case			
<input type="checkbox"/> Embroidered Bag	<input type="checkbox"/> Sword Bag	<input type="checkbox"/> Koikuchi-kun		
<input type="checkbox"/> Shirasaya Bag	<input type="checkbox"/> Fusa	<input type="checkbox"/> Kashira		
<input type="checkbox"/> Tsuba	<input type="checkbox"/> Fuchi	<input type="checkbox"/> Shitodome		
<input type="checkbox"/> Menuki	<input type="checkbox"/> Seppa	<input type="checkbox"/> Tsunagi	<input type="checkbox"/> Kojiri	
[In the Box]				
Sword in Shirasaya・Sword in Koshirae	<input type="checkbox"/> W/ Sageo			
Saya Only・Tsuka Only・Blade Only	<input type="checkbox"/> W/ Habaki			
<input type="checkbox"/> Kissaki Damaged	<input type="checkbox"/> Mune Rust			
<input type="checkbox"/> Chip in Blade	<input type="checkbox"/> Scratch			
<input type="checkbox"/> Estimate Sent(/) / <input type="checkbox"/> Transfer Form Sent / <input type="checkbox"/> Pay Later	[Payment Status] Complete(/) / Partial(¥)			
Kashira Shape (Round・Flat・Horn)	Tsuba (Attached to sword・Nosyudo Provided in box)	Seppa (Attached to sword・Nosyudo Provided in box)	Metal Kojiri (Y・N)	
			From Koikuchi (en-trust・cm)	
			From Kissaki (en-trust・cm)	
Tsuka Length (sun bu/cm)			Koikuchi Shape (Standard・Takatsuno)	
			Saya Thickness (Standard・)	
Habaki (Attached to sword・Nosyudo Provided in box)	Fuchi・Shitodome (Kashira・Kurigata)	Menuki (Attached to sword・Nosyudo Provided in box)	Saya Finish ()	
Tsuka Width (Standard・Thick・Thin)	Tsuka Shape (Standard・Egg・Flat・Yagyu)	Menuki Position (Standard・Center・Reverse)	Tsuka Color & Material (Black・)(Cotton・Silk・Cow・Pig (F・B))	
Same Color (White・Black・Antique・Black&Red)	Tsukamaki (Hinerimaki・)	Tsunagi (Y・N)		
Oyasame (Y・N)	Carve Bo-hi (Y・N)	Desired weight reduction (g)()		
Same Wrap (Tanzaku・Makizame)		Desired sound?()		

[Please Note]

① We handle each item with great care, however there are sometimes circumstances beyond our control that we cannot take responsibility for. Please keep this in mind this when submitting items for repair.

② We only ship after payment is completed.

Shinken Order Form

FAX (0575)22-2383

©Desired Completion Date

Customer Contact Info

Name: _____ TKC: _____ Dojo: _____
 Address _____ Phone·Fax: _____
 _____ Cell: _____
 _____ PC e-mail _____

Payment Method: Bank Transfer · Convenience Store Transfer · Credit Card · COD · Paypal · Other :

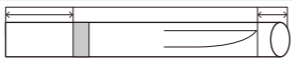
Blade	Gendai Shinken	For Iaido · Battodo · Appreciation
	Swordsmith	Request (_____ saku) · Nosyudo's recommendation
	Blade Length	(_____ shaku sun bu) (_____ cm)
	Sori	(_____ bu) (_____ cm) ※standard 1.5cm~1.8cm
	Nakago Length	(_____ sun bu) (_____ cm) ※Standard, 7sun 5bu (22.7cm)
	Number of Mekugi-Ana	(_____) ※usually 1 ※2 for batto
	Hamon	(_____) ※gunome, suguha, smith's specialty · surprise me
	Bo-Hi	(with · without) ※standard, kakinagashi (ends under the habaki) : ※marudome (ends before the habaki) ※kakitoshi (goes to the end of the nakago)
	Target Weight Without Saya	(_____ g ~ _____ g)
	Weight After Forging	(_____ g)
	Kissaki Length	(_____ mm) ※from kissaki to yokote ※usually 33mm~36mm
	Motohaba	(_____ mm) ※at habaki
	Motokasane	(_____ mm) ※at habaki
Sakihaba	(_____ mm) ※at yokote	
Sakikasane	(_____ mm) ※at yokote	
Tsuka	Tsukaito Material	(_____) [cotton · silk · cow leather (front · back) · pig leather (front · back)]
	Tsukaito Color	(_____) [black · antique · steel blue · azuki · other]
	Tsukamaki Type	(_____) [hinerimaki · tsumamimaki · katatemaki] ※Standard is hinerimaki
	Menuki Position	(_____) [standard · center · reverse · other]
	Tsuka Length	(_____ sun bu) (_____ cm) ※total length
	Tsuka Width	(_____) [thin · slightly thin · standard · slightly thick · thick] ※Please send us a copy of your hand
	Tsuka Shape	(_____) [standard · egg · flat · ryugo (drum/hour glass shaped) · yagyū (flat on mune side)]
	Tsuka Base	(Base for tanzaku · makizame) ※Standard is tanzaku (magnolia · sakura) ※Standard is magnolia
	Same Attachment	(_____) [tanzaku · makisame] ※tanzaku is standard ※makisame costs extra
	Oyasame/Same with Bumps	(with · without) ※usually with
Same Color	(_____) [white · black · antique · other] ※Standard is antique (light brown)	
Saya	Saya Finish	(SY— : _____)
	Kurigata Position	(From Koikuchi _____ cm) ※Usually 7.5cm from koikuchi ※6.5cm for small hands, 8.5cm for large hands
	Saya Length	(from kissaki _____ cm) or total saya length(_____ cm)  ※usually 3cm from kissaki
	Kurigata Shape	(standard · other : _____) ※standard is round higo-style water buffalo horn
	Metal Kurigata	(with · without) ※we use water buffalo horn on standard kurigata
	Shitodome for Kurigata	(with · without) ※usually without (it can cut the sageo)
	Koikuchi Shape	(standard · takatsuno) ※standard is a flat, smooth koikuchi
	Metal koikuchi	(with · without) ※we use water buffalo horn on standard koikuchi
	Metal Kojiri	(with · without) ※Kuwagata kojiri may cost extra
	Extra Saya	(with · without) ※Stock saya (awase saya) ※Hon saya (handmade) ※Yasume saya (Shirasaya saya only · Unpainted stock saya)
Other	Please inform us if you want special additions such as kizami or sayamaki. (_____)	
Metal Fittings	Tsuba	(T— : _____) catalog · customer-provided ※for customer-provided tsuba (semegane necessary)
	Tsuba Plating (Rust Resistant)	(with · without) [Aged Brass · Aged Silver]
	Fuchi Kashira	(KS · KY— : _____) [catalog · customer-provided silver=KS aged brass=KY
	Kojiri	(with · without) (KS · KY— : _____) catalog · customer-provided ※kojiri shape (funagata · kuwagata)
	Menuki	(MS · MY— : _____) [catalog · customer-provided] ※silver=MS aged brass=MY
	Seppa	(_____) ※ (ready-made) brass · silver plated · gold plated ※ (handmade) copper · silver · gold
	Habaki	(_____) ※ (handmade) copper · silver (yujo · shonai) gold single · gold double · other
Polish	Polish	(best · middle · regular) ※calculated using blade length (_____) × 1sun (¥)
	Carving Bo-hi	(with · without) kakinagashi · marudome · kakitoshi ※standard is kakinagashi ※depending on the blade, the weight could be reduced by 130g-150g (including rough polish)

<Note> The customer is responsible for shipping expenses in all cases, including repeated attempts.



濃州刀剣工房

有限会社 濃州堂 内

古物商許可
岐阜県公安委員会第531140001207号
https://nosyudo.jp/shop/



What is Nosyu Sword Studio

Our company not only accepts orders for active sword smiths and has koshirae made for shinsakuto, but also buys and sells Japanese swords from as far back in Japanese history as the Kamakura period.

In addition to our swords for martial arts, we also have a large

selection of swords for appreciation available. We can also use antique metal fittings available in the Sword Studio to make koshirae for shinken and iaito. Your selection may be limited by the dimensions of the sword, but you are more than welcome to contact us about our selection.

Shopping at Nosyu Sword Studio

- We accept inquiries about our selection via phone, fax, and the "Contact Us" section of our homepage. Please also note the product number if the product has one.
 - We accept the payment methods listed on page 48. Your items will be shipped upon completion of payment.
 - We provide a "Meigi Henko Yoshi", a transfer of registration form, with the registration card for the sword to customers living in Japan after the purchase is complete. We highly recommend you make at least one copy of the registration card as a backup. Write your address, name, etc and mail the form in the provided envelope and the transfer is complete. You do not need to contact the police.
 - We expect the customer to cover shipping in all cases including repeated attempts.
 - Our prices are dependent on the quality of the item. We accept returns and trade-ins of purchases made more than three months ago, but it is dependent on whether or not it has been damaged after the purchase. Nosyu Sword Studio has the right to deny a return based on these factors. We'll process exchanges within 3 months of the return of the item via money transfer.
 - Let us know if you'd like to trade in an item during a purchase.
- Trades and sales of swords the customer bought from Nosyu Sword Studio are treated independently from the original sale.
- We offer 60% of the value of koto, shinto, and shinshinto at and 50% of the price for gendaito for trade-ins.
- We offer 50% of the value of koto, shinto, and shinshinto and 40% of the value of gendaito when purchasing.
- In the case of swords for martial arts, the current condition and whether or not it needs repairs can affect the offered price.
- We accept Japanese swords and their accessories, koshirae, and various fittings for trade and sale. We do not accept iaito in under circumstances.
 - We accept payment in up to 36 installments through Orient Corp (Orico) from domestic customers.
 - Prices include tax.

Thank you very much for perusing previous editions of our catalog. Please check out our website for a wide selection of new and antique products.



https://nosyudo.jp/shop/

濃州堂 通販

検索

Cut Here